



Houston Fire Department Life Safety Bureau (LSB)



LSB Standard No. 05, Rev. 04

Key Boxes

Supersedes: LSB Standard No. 05, Rev. 03, 05/01/2012

Effective Date: 11/02/21



LSB Standards are established in accordance with provisions of the City of Houston *Fire Code*. They are subject to the administrative sections covering alternative materials and methods, modifications, and the Board of Appeals.

Table of Contents

Section 5.1 – General..... 3

 5.1.1 Scope. 3

 5.1.2 Purpose. 3

Section 5.2 – Definitions..... 4

 5.2.1 Falcon Mortise Cylinder. 4

 5.2.2 Falcon Padlock. 4

 5.2.3 Key Box/"9-1-1" Box. 4

Section 5.3 – General Requirements 4

 5.3.1 Where Required..... 4

 5.3.1.1 Access Control Gates and Barriers. 4

 5.3.1.2 High-Rise Buildings. 4

 5.3.2 Box Construction. 4

 5.3.3 Location. 5

 5.3.4 Locking Device. 5

 5.3.5 Approval. 5

Section 5.4 – High Voltage Electric Fences 5

 5.4.1 High Voltage Key Box Construction and Maintenance. 5

 5.4.2 High Voltage Key Box Location. 6

 5.4.3 High Voltage Fence Registration. 6

Section 5.5 – Permit..... 6

 5.5.1 Required. 6

Appendix A – Key Boxes..... 7

 Figure No. 1 – Typical Key Box/"9-1-1" Box (Open with Padlock Removed)..... 7

 Figure No. 2 – Typical Key Box/"9-1-1" Box (Closed with Padlock)..... 8

 Figure No. 3 – Key Box/"9-1-1" Box with Falcon Mortise Cylinder..... 9

References..... 10

Key Boxes

Section 5.1 – General

5.1.1 Scope.

This standard provides a method of providing for and maintaining adequate and unobstructed emergency access for Fire Department apparatuses and personnel to buildings, structures, hazardous occupancies, or other premises within the City of Houston as may be required by the Fire Marshal, Chief of the Houston Fire Department, and the Houston *Fire Code*.

5.1.2 Purpose.

The purpose shall be to provide clarification of requirements and guidance to persons charged with providing and maintaining required fire department access to premises in compliance with the *Fire Code*. The provisions of this standard are general in nature and are not intended to override the specific requirements of City of Houston *Code of Ordinances* of the *Fire Code*.

This standard is subject to periodic review and update to accommodate changes in local need or requirements, changes in nationally recognized standards, changes in related technology, or changes required by state or federal regulations.

Notice: Where references in this standard are made to products manufactured by “Falcon Locks” and related “9-1-1” Boxes, certain products manufactured by the “Knox Company” have been approved for voluntary use in lieu of “Falcon Lock” products and the “9-1-1” Boxes. All key boxes shall comply with UL 1037.

Approved items manufactured by the “Knox Company” may be referenced online at www.knoxbox.com.

The following is a list of “Knox Company” products that are allowed to be used inside the City of Houston City Limits.

- Fire Depository Box
- Electrical Shutdown Box
- Keyswitch
- Padlock
- FDC 2½ inch Locking Cap
- SecureCap
- Cabinets (1300 Series)
- 3200 Series Box, Single-Key Style, ONLY with the hinged lid.
- 4100 Series Box

The Fire Marshal’s final approval and a permit are required for the installation and use of any “Knox Company” or “Falcon Lock” product.

Section 5.2 – Definitions

5.2.1 Falcon Mortise Cylinder.

A type of Falcon lock used with the operation of electronically controlled gates. This is a keyed device that causes a gate to open when a “9-1-1” key is inserted in the mortise cylinder keyhole and turned. Only authorized emergency service personnel retain keys to these locks.

5.2.2 Falcon Padlock.

An approved “9-1-1” padlock that may be applied to “9-1-1” gate operations, obtainable only from certain gate companies or contractors. Only authorized emergency service personnel retain keys to these padlocks.

5.2.3 Key Box/”9-1-1” Box.

A tamper proof box secured with a lock operable by an approved fire department key or other approved means as provided for in Section 5.3.4 of this standard intended to hold the contents required by applicable LSB Standards.

Section 5.3 – General Requirements

5.3.1 Where Required.

When access to or within a structure or an area is unduly difficult because of secured openings or where immediate access is necessary for life-saving or firefighting purposes, the Fire Marshal is authorized to require an approved key box or “9-1-1” box to be installed in an accessible location. The key box shall be of an approved type listed in accordance with UL 1037 and shall contain all necessary keys to gain access to the structure or area. In addition to keys, the key box shall contain other items determined to be necessary by the Fire Marshal for the effective response of fire department personnel to an emergency at the premises.

5.3.1.1 Access Control Gates and Barriers.

For Key Box/”9-1-1” Box use on access control gates and barriers, refer to LSB Standard No. 04, “Access Control Gates.”

5.3.1.2 High-Rise Buildings.

A key box, used by the fire department to obtain building access, shall be installed on all high-rise buildings.

Exception: The Fire Marshal may waive this requirement for buildings that have qualified, on-site personnel who are available at all times to provide immediate building access for the fire department.

5.3.2 Box Construction.

A key box shall be constructed and listed to meet UL 1037. The key box shall be of size sufficient to contain all keys, swipe cards, and other required items as may be deemed necessary by the Fire Marshal (for minimum box dimensions see Appendix A). The front

of the key box shall be hinged and designed so that it can be secured by a Falcon mortise cylinder or designed with a pad-eye so that it can be secured by an approved padlock.

The key box shall be painted any color approved by the Fire Marshal, provided that the door of the box shall be painted bright red so as to be readily noticeable and have the words **"FIRE DEPARTMENT"** or the number **"9-1-1"** painted in white letters not less than 1-inch in height (see Appendix A).

5.3.3 Location.

The key box shall be installed on the exterior of a structure or building, as near as practicable to the main entrance door or designated emergency access door. The key box should be located within 48 to 60 inches above the ground level and securely affixed to a wall, post, or column so that it is not loose or movable. The key box shall be positioned so that it is readily apparent upon approach to the door.

At locations where hazardous materials are stored in quantities requiring fire department permits and at warehouse locations, the key box shall be located at the main fire department access entrance to the facility, at a guard shack, gate house, or similar location. Where no guard station or gate house is provided, then a weather resistant "9-1-1" box, large enough to contain all required Hazardous Materials Inventory Sheets, floor plans, and access keys shall be provided at a readily identifiable and accessible location that will not be endangered by fire in the facility.

5.3.4 Locking Device.

Key boxes may be locked with a Falcon mortise cylinder, Falcon padlock, or a padlock of a design that can be cut open with standard bolt cutters carried on emergency apparatuses. "Shankless," short shank, or super hardened locks shall not be allowed.

5.3.5 Approval.

Fire Department approval is required to install and maintain key boxes for access to or within such structures or properties as office buildings, residential buildings, nursing homes, hospitals, school buildings, industrial plants and facilities, hazardous materials storage buildings, large storage buildings, or other structures the Fire Marshal may require. Approval shall be obtained through the permitting process prior to final installation of a key box or "9-1-1" box.

Section 5.4 – High Voltage Electric Fences

5.4.1 High Voltage Key Box Construction and Maintenance.

The key box for a high voltage fence shall be constructed of metal materials that are weather resistive and of sufficient strength and thickness to deter forced entry. The front of the key box shall be hinged and designed so it can be secured by an approved Falcon mortise cylinder or designed with a pad-eye that can be secured by an approved padlock.

The key box used for a high-voltage fence shall be painted a bright "RED" color and have the words **"FIRE DEPARTMENT"** or the numbers **"9-1-1"** painted in at least 1-inch "WHITE" letters or numbers on the front of the key box. The front of the key box shall also be labeled **"HIGH VOLTAGE KEY BOX"** in white letters at least 1-inch in height.

The key box should be of a size sufficient to contain red and green indicator lights, a “mushroom” pushbutton no less than 1½ inches in diameter, and other required items as may be deemed necessary by the Fire Marshal. The indicator lights shall be readily visible and mounted on the interior of the box. The red light shall be labeled “Energized” and the green light shall be labeled “Deactivated” in letters that are readily visible. The mushroom pushbutton shall be labeled “Push to Deactivate Fence.” Deactivating the fence shall be accomplished by pushing the mushroom pushbutton. Once the mushroom button is pushed, it shall immediately activate a relay system, deactivating the fence and shall causing the red light to turn off and the green light to illuminate. The key box and all components shall be maintained in proper working condition at all times.

5.4.2 High Voltage Key Box Location.

The key box for a high voltage fence shall be located at the main fire department entrance as approved by the Fire Marshal and shall be outside the perimeter fence or wall. The “9-1-1” box shall be located within 48 to 60 above ground level and securely affixed so as not to be loose or moveable. At no time shall the “9-1-1” box be in contact with any part of the high voltage fence or perimeter fence.

5.4.3 High Voltage Fence Registration.

Prior to installing any high voltage fence, the responsible party shall submit a completed “Houston Fire Department Electric Fence Registration Form” to the fire code official. Prior to making any changes to a registered electric fence, including but not limited to, alterations to the original fence design and construction, or relocation of the high voltage key box, the responsible party shall submit a new registration form to the fire code official that identifies the changes made.

Section 5.5 – Permit

5.5.1 Required.

A permit is required to install and maintain a key box or “9-1-1” box. This permit shall be renewed annually.

Permit Office contact information is as follows:

The Houston Permitting Center

1002 Washington Avenue

Houston, Texas 77002

Hours of operation: 8:00am to 3:30pm (CST)

Monday through Friday

Office phone: (832) 394-8811

To E-mail Customer Service Questions: hfd.permitoffice@houstontx.gov

Link to City Wide Fee Schedule: www.houstoncityfees.org

Appendix A – Key Boxes

Figure No. 1 – Typical Key Box/"9-1-1" Box (Open with Padlock Removed)

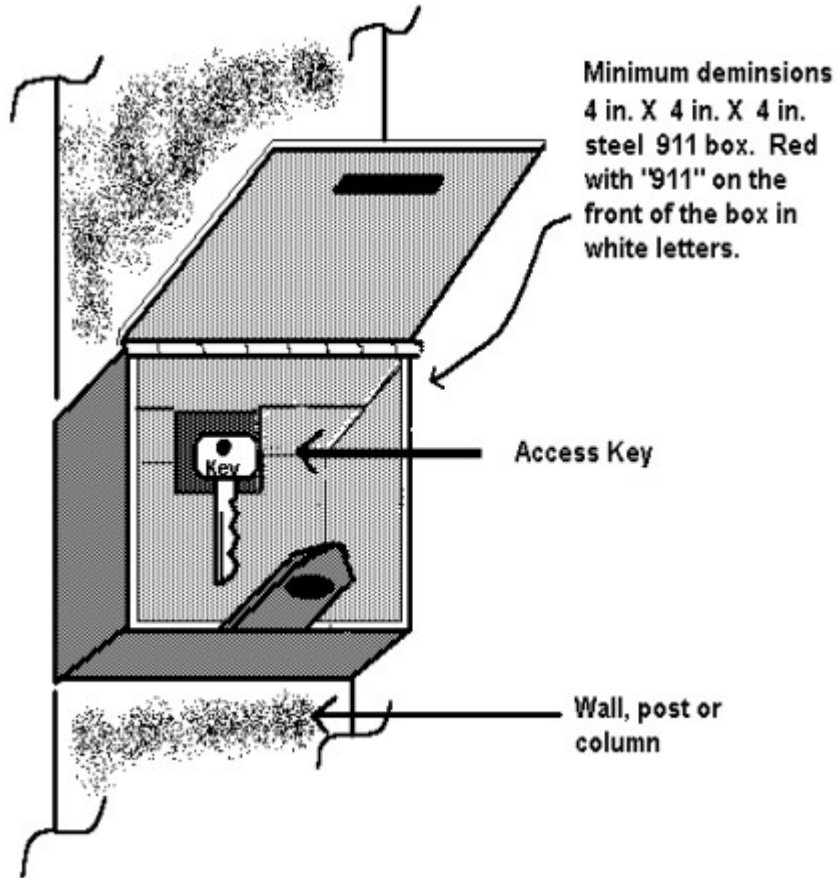

Figure No. 2 – Typical Key Box/"9-1-1" Box (Closed with Padlock)

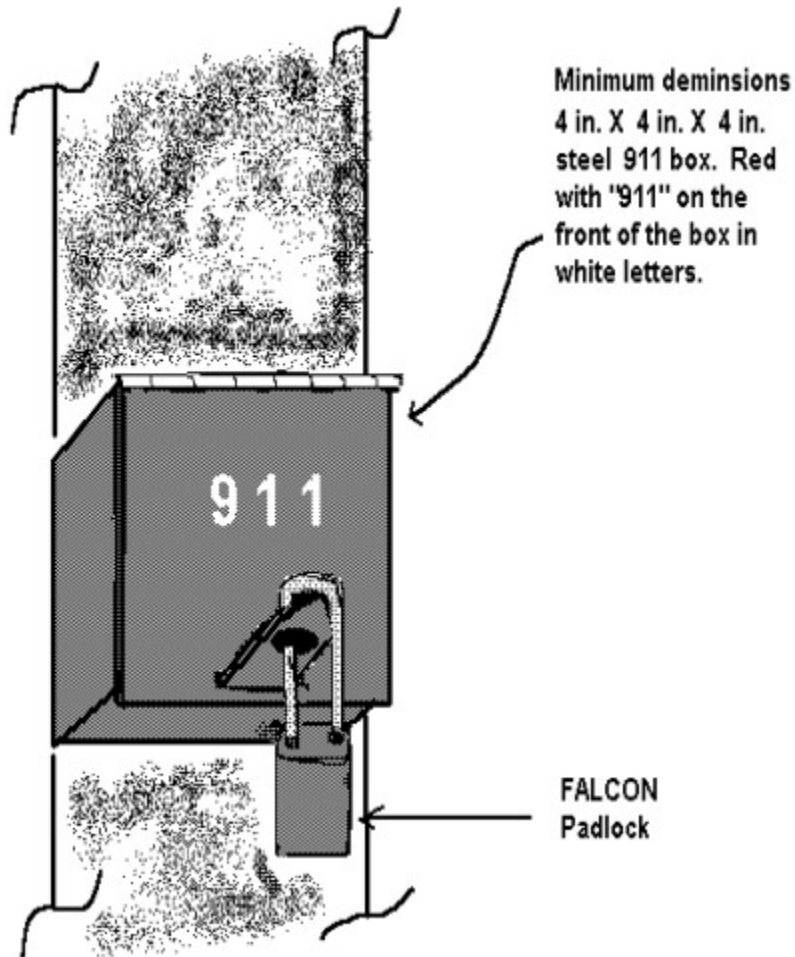
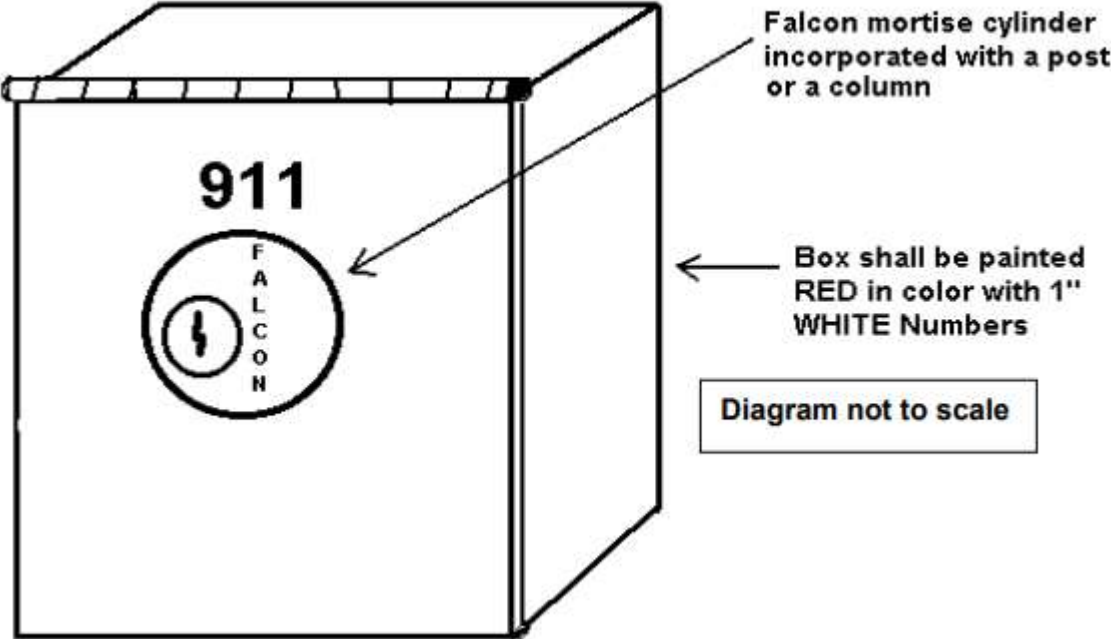

Figure No. 3 – Key Box/"9-1-1" Box with Falcon Mortise Cylinder



References

1. City of Houston *Fire Code*.
2. Life Safety Bureau (LSB) Standard No. 03, "Fire Department Access."
3. Life Safety Bureau (LSB) Standard No. 04, "Access Control Gates."
4. Life Safety Bureau (LSB) Standard No. 06, "Fire Depository Boxes."

All reference materials used under this Life Safety Bureau standard shall be in accordance with the most current adopted City of Houston *Construction Code*.