



# Houston Fire Department Life Safety Bureau (LSB)



## LSB Standard No. 04, Rev. 05

### **Access Control Gates**

*Supersedes: LSB Standard No. 04, Rev. 04, 12/31/2010*

**Effective Date: xx/xx/xx**



---

LSB Standards are established in accordance with provisions of the City of Houston *Fire Code*. They are subject to the administrative sections covering alternative materials and methods, modifications, and the Board of Appeals.

## Table of Contents

Section 4.1 – General.....	4
4.1.1 Scope. ....	4
4.1.2 Purpose. ....	4
Section 4.2 – Definitions.....	5
4.2.1 Access Control Gate or Barrier.....	5
4.2.2 Fire Apparatus Access Road.....	<b>Error! Bookmark not defined.</b>
4.2.3 “Fail-Safe” Operation.....	<b>Error! Bookmark not defined.</b>
4.2.4 Falcon Padlock.....	5
4.2.5 Falcon Lock Mortise Cylinder.....	5
4.2.6 Gate Operation.....	5
4.2.7 Private Drives.....	5
4.2.8 Private Street or Road.....	6
4.2.9 Public Street.....	6
4.2.10 Reader/Reader Appliance.....	6
4.2.11 “9-1-1” Box.....	<b>Error! Bookmark not defined.</b>
Section 4.3 – General Requirements .....	6
4.3.1 Approval Required.....	6
4.3.2 Gate Width Operations.....	6
4.3.2.1 Gates on Dedicated Private Streets, At the Entrance to Residential Development Projects.....	6
4.3.2.2 Gates on Private Drives at Entrances to Residential Development Projects. .....	7
4.3.2.3 Access Control Gate/Barrier on Fire Apparatus Access Roads, At Hazardous Material Sites, Group H Occupancies, and High-Pile Combustible Storage Sites. ..	7
4.3.3 Gate Opening Devices and Approvals.....	9
4.3.4 Existing Gates and Barriers.....	9
4.3.5 Gates on High Voltage Fence.....	9
4.3.6 Vertical Clearance.....	9
4.3.7 Approval Requirement.....	10
4.3.7.1 Letter of Explanation.....	10
4.3.7.2 Requirements for Drawings (Plans) of Gates/Barriers.....	10
4.3.7.3 Additional Information (As May Be Required).....	10
4.3.8 Permits Required.....	11
Appendix A – Automatic and Manual Swing Combination Gate.....	12

Enclosure No. 1 – Automatic and Manual Swing Gate Combination .....	13
Enclosure No. 2 – “Fail-Safe” On A Swing Gate Arm .....	14
Enclosure No. 3 – “Fail-Safe” On Swing Gate .....	15
Appendix B – Manual Swing and Automatic Slide Gate .....	16
Enclosure No. 1 – Manual Swing and Automatic Slide Gate .....	17
Appendix C – 13-Foot Automatic Slide Gates .....	18
Appendix D – 14-Foot Automatic Slide Gates .....	19
Appendix E – Falcon Mortise Cylinder “9-1-1” System.....	20
Enclosure No. 1 – “9-1-1” Mortise Cylinder Boxes.....	21
Appendix F – “9-1-1” Box and “Re-Set” Box.....	23
Appendix G – Automatic System Using A Micro-Switch.....	24
Appendix H – “9-1-1” and “Fail-Safe” Systems on Electric Gates .....	25
Appendix I – “Fail-Safe” Cable Assembly on Electrically Operated Swing Gates.....	26
Appendix J – “Fail-Safe” Emergency Illustration .....	27
Appendix K – Fold Down Hinge System.....	28
Appendix L – Spring-Loaded “Drop Rod” Assembly.....	29
Appendix M – Access Control Barriers.....	30
Appendix N – Performance Standards.....	31
Appendix O – Procedure for Submittal for Gate (Barrier) Approvals .....	32
Appendix P – Key Boxes.....	34
Figure No. 1 – Typical Key Box/”9-1-1” Box (Open with Padlock Removed).....	34
Figure No. 2 – Typical Key Box/”9-1-1” Box (Closed with Padlock).....	34
Figure No. 3 – Key Box/”9-1-1” Box with Falcon Mortise Cylinder.....	35
References.....	35

# Access Control Gates

## Section 4.1 – General

### 4.1.1 Scope.

This standard addresses the provisions and maintenance of adequate and unobstructed emergency access for fire department apparatuses and personnel to buildings, structures, hazardous occupancies, or other premises, as may be required by the Fire Marshal, Chief of the Houston Fire Department, and the *Fire Code*, within the City of Houston

### 4.1.2 Purpose.

The purpose of this standard shall be to provide clarification of requirements and guidance to the person charged with providing and maintaining required fire department access to premises in compliance with the *Fire Code*. The provisions of this standard are general in nature and are not intended to override the specific requirements of City of Houston *Code of Ordinances* or the *Fire Code*.

This standard is subject to periodic review and update to accommodate changes in local needs or requirements, changes in nationally recognized standards, changes in related technology, or .changes instate or federal regulations.

**Notice:** Where references in this standard are made to products manufactured by “Falcon Locks” and related 9-1-1 boxes, certain products manufactured by the “Knox Company” have been approved for voluntary use in lieu of “Falcon Lock” products and the 9-1-1 boxes. All key boxes shall comply with UL 1037.

Approved items manufactured by the “Knox Company” may be referenced online at [www.knoxbox.com](http://www.knoxbox.com).

The following is a list of “Knox Company” products that are allowed to be used inside the City of Houston city limits:

- Fire Depository Box
- Electrical Shutdown Box
- Keyswitch
- Padlock
- FDC 2½ inch Locking Cap
- SecureCap
- Cabinets (1300 Series)
- 3200 Series Box, Single-Key Style, ONLY with the hinged lid.
- 4100 Series Box

The Fire Marshal’s final approval and a permit are required for the installation and use of any “Knox Company” or “Falcon Lock” product.

## **Section 4.2 – Definitions**

### **4.2.1 “9-1-1” Box.**

A tamper proof box secured with a lock operable by an approved fire department key or other approved means as provided for in LSB Standard No. 05, “Key Boxes” that contains: emergency keys, access door lock, gate or barrier release, or deactivation devices, and in addition, may contain such information as required by the fire department to affect safe and ready access to a property, building, or structure in event of an emergency. The key box shall be of an approved type listed in accordance with UL 1037. (2015 IFC 506.1)

### **4.2.2 Access Control Gate or Barrier.**

Any gate or barrier placed across a fire apparatus access road to restrict other vehicles or use. Access control barriers may include, but are not limited to: chains, bars, barricades, or similar devices or construction. Tire spikes shall not be used to restrict a fire apparatus access road. Where a swing gate or swing barrier is provided, it shall swing in the direction towards the property.

### **4.2.3 Falcon Padlock.**

An approved “9-1-1” padlock that may be applied to “9-1-1” gate operations, obtainable only from certain gate companies or contractors. Only authorized emergency service personnel retain keys to these padlocks.

### **4.2.4 Falcon Mortise Cylinder.**

A type of Falcon lock used with the operation of electronically controlled gates. This is a keyed device that causes a gate to open when a “9-1-1” key is inserted in the mortise cylinder keyhole and turned. Only authorized emergency service personnel retain keys to these locks.

### **4.2.5 Fire Apparatus Access Road.**

A designated road or lane provided so that fire department apparatus can approach or obtain entrance to a building, structure, or other property in event of a fire or other emergency situation.

### **4.2.6 “Fail-Safe” Operation.**

A manual operation of electronic slide or swing gates that can be used in the event of power failure or equipment malfunction.

### **4.2.7 Gate Operation.**

A gate operation or function, such as: manual, electronic, swing arm, chain drive; entry devices (such as a card reader, key pad, telephone); direction of gate swing; fail safe methods.

### **4.2.8 Private Drive.**

A privately owned and maintained access way used for vehicular travel that is not a street or private street and that provides an unobstructed connection between one or more streets or private streets or from a street or private street to any portion of a parking lot, shopping center, institution, commercial area, or industrial development.

A private drive may provide for access by the general public, but the owner of the private drive maintains the right to restrict public access to the private drive.

#### **4.2.9 Private Street or Road.**

A privately owned and maintained vehicular access way that provides access to a property from a public street.

Private streets are required by Section 42-231(b)(1) of the *City Code* to have a minimum right-of-way width of 28 feet. All openings or access points from the public streets to the private streets in a residential development project are considered to be “entrances” by definition.

#### **4.2.10 Public Street.**

A public right-of-way, however designated, dedicated, or acquired, that provides access to adjacent property.

#### **4.2.11 Reader/Reader Appliance.**

A device such as a card reader, swipe card reader, key punch, telephone, or similar device that when activated will provide for the unlatching, unlocking, or opening of an access control gate or barrier.

### **Section 4.3 – Access Control Gate or Barrier Approval General Requirements**

#### **4.3.1 Approval Required.**

A “Fire Marshal Approval” permit is required to install and maintain an access control gate or barrier on a private drive, street, or road into such properties as residential development projects, nursing homes, hospitals, schools, industrial plants and facilities, hazardous materials storage or disposal sites, Group H occupancy sites, high-piled combustible storage sites, large storage sites, or other sites as the Fire Marshal may require. Approval by the Fire Marshal shall be obtained *prior* to installation of an access control gate or barrier.

#### **4.3.2 Gate Widths, Required Operations, and Construction Documents.**

Requirements are as follows:

##### **4.3.2.1 Gates on Dedicated Private Streets, At the Entrance to Residential Development Projects.**

1. Two 14-foot gates that open to provide access to the full 28-foot street width at a project entrance; or

**Note:** The 28 feet of access is also required when the gate is operated using a “Fail-Safe” method.

2. One 28-foot gate that opens to provide access to the full 28-foot street width at a project entrance; or
3. Two gates, a minimum of 13-foot width each, with a maximum of 2 feet allowed in the middle of a private street for readers or similar devices and/or

center post at a project entrance. (13 feet + 2 feet for a reader + 13 feet = 28 total feet minimum); or

4. Where any private street is less than 28 feet in width (for example, where there are 20-foot streets divided by esplanades), then the entire width of the street shall be accessible without any obstruction in the street when the gates are open. The width of the gates may vary to accommodate the width of the street.

**Note:** All openings or access points from public streets to the private streets in a residential development project are considered to be “entrances” by definition.

#### **4.3.2.2 Gates on Private Drives at Entrances to Residential Development Projects.**

1. One 14-foot gate that opens to provide at least 14 feet of access width where the drive is less than 28 feet; or
2. Two gates, a minimum of 13 feet wide each, where the drive is 28 feet wide; or.
3. One 28-foot gate that opens to provide at least 28 feet of access where the drive is 29 feet wide.

#### **4.3.2.3 Access Control Gate/Barrier on Fire Apparatus Access Roads, At Hazardous Material Sites, Group H Occupancies, and High-Piled Combustible Storage Sites.**

##### **4.3.2.3.1 Dimensions.**

Access control gate/barriers shall have an unobstructed width of not less than 20 feet and an unobstructed vertical clearance of not less than 13 feet, 6 inches.

##### **Exceptions:**

1. When approved by the fire code official, vertical clearance may be reduced, provided the reduction does not impair access by fire apparatus and approved signs are installed and maintained indicating the established vertical clearance.
2. When approved by the fire code official, existing access control gate/barriers may have an unobstructed width of not less than 15 feet (4572 mm) when the reduction in width will not impair access by fire department equipment. (2015 IFC 503.2.1)

The fire code official shall have the authority to require an increase in the minimum access widths where they are inadequate for fire or rescue operations. (2015 IFC 503.2.2)

##### **4.3.2.3.2 Construction Documents for Access Control Gate/Barrier.**

Construction documents for proposed fire apparatus access and any access control gate/barrier shall be submitted by the property owner or the

owner's authorized agent to the Hazardous Materials/High-Piled Combustible Storage Inspection Team, 1002 Washington Avenue, Houston, Texas 77002, for review and approval prior to construction (2015 IFC 501.3)

The following information must be included:

- Width of the gate/barrier openings.
- Type of gate or barrier operation: slide, swing, etc.
- Distance from the access roads to the gates/barriers.
- Distance from the gate to the reader.
- Location and type of reader.
- Location of the "9-1-1" Box shall be in accordance with Appendix P for key box details.
- Location and type of the hold open devices.
- Location and type of the automatic opening devices.
- Identification of any vertical clearance obstructions.
- Notes indicating: Gates are to be automatically open and remain open until closed manually.
- Notes indicating: Gates/barriers must remain open at all times until a fire prevention inspector has made a final "on-site" inspection and approval.

#### **4.3.2.3.3 Automatic Swing or Slide Gates.**

The gate shall be twenty (20) feet in width. A "9-1-1" Box and a "Fail-Safe" Box shall be installed on the gatepost at a height not to exceed five (5) feet. When approved by the fire code official, the "9-1-1" Box and the "Fail-Safe" Box may be combined. For "9-1-1" Box specifications and details, see Appendix P.

##### **4.3.2.3.3.1 Electrically Powered Gates.**

The "9-1-1" Box shall be provided with an electrical switch (toggle or micro-switch with button). Moving the toggle switch to the "Up" position will cause the gate to swing open towards the project or roll or slide to a fully open position. The micro-switch shall automatically activate once the hinged lid on the "9-1-1" Box is opened (see Appendix G). The gate shall remain open until the toggle switch is returned to its original position.

##### **4.3.2.3.3.2 Falcon Mortise Cylinder "9-1-1" Box.**

Shall be in accordance with Appendix E.

##### **4.3.2.3.3.3 Fold-Down Hinge Gates.**

The key located in the "9-1-1" Box shall be capable of opening the lock located on a fold-down hinge (see Appendix K). When the lock is removed, the hinge shall fall down flat towards the project property on the access road, and the gate shall open automatically by springs



or counterweight. "Duckbill" catches behind the gate shall hold the gate open until manually closed.

#### **4.3.2.3.4 Automatic Swing Gates (Fail-Safe System).**

For instances when power is interrupted or a mechanical malfunction occurs rendering the access gate not operable, a key shall be provided in the "9-1-1" Box that will unlock the lock attached to a pin in the arm of the operator causing the pin to fall towards the ground (see Appendix A, Enclosure No. 2 and 3) rendering the gate manually operable and able to be opened manually to its full width (20 feet). Any obstruction preventing the gate from being fully operational, whether part of the gate assembly or not, shall be corrected prior to Fire Marshal approval. "Duckbill" catches behind the gate will hold the gate open until manually closed or repairs can be made to return the gate to normal operation.

#### **4.3.3 Gate Opening Devices and Approvals.**

Gate opening devices and approval shall be the same as those required for gates installed on private streets as specified above.

#### **4.3.4 Existing Gates and Barriers.**

"Approved" gates/barriers shall mean those gates/barriers with written approval from the Fire Marshal. Plans for any remodeling or rebuilding of approved gates/barriers that will change the gate/barrier opening or opening device must be resubmitted to the Fire Marshal for approval.

#### **4.3.5 Gates on High Voltage Fence.**

Gates used in conjunction with a High Voltage Electric Fence as allowed by Section 28-10 of the City of Houston *Code of Ordinances* shall not be electrically charged and shall be designed so that when the gate makes contact with any part of a charged fence, the fence and gate will ground. Signs shall be placed on gates (other than the main entrance as approved by the fire code official) stating "9-1-1 High Voltage Key Box Located at Main Entrance." Signs shall be YELLOW in color with letters in contrasting color and shall be of a size that is readily visible at all times. Gates used with a High Voltage Fence shall comply with all other applicable regulations found in this standard and the Houston *Fire Code*.

#### **4.3.6 Vertical Clearance.**

Unobstructed vertical clearance of not less than 13 feet, 6 inches shall be maintained over the full width of all fire department access roads, drives, and gates.

##### **Exceptions:**

1. Vertical clearance may be reduced upon approval of the Fire Marshal, provided such reduction does not impair access by fire apparatus and approved signs are installed and maintained indicating the established vertical clearance.

2. Vertical clearance may be reduced with approved over-height warning indicators.

Vertical clearances or widths shall be increased when, in the opinion of the Fire Marshal, vertical clearances or widths are not adequate to provide fire apparatus access.

#### **4.3.7 Approval Requirement.**

##### **4.3.7.1 Letter of Explanation.**

A letter of explanation, submitted by the gate contractor, shall be provided to the Fire Marshal's Office for approval that explains the scope of work associated with the installation in detail, including details of the operational function of the system and shall include, but not be limited to:

- The type of operation (function) applicable to the "9-1-1" Box (Mortise cylinder, toggle switch, key, etc.).
- How the "Fail-Safe" system works. (The "Fail-Safe" must be able to be activated on the *same side of the gate* as the "9-1-1" Box. A firefighter *shall not* be required to insert an arm through a gate to use a "Fail-Safe" key or other device.)
- Manual override operations are required on electrically operated gates.
- Gates must open without delay.
- Other necessary information.

##### **4.3.7.2 Requirements for Drawings (Plans) of Gates/Barriers.**

Plans shall include, but not be limited to, the following minimum specific information:

- Width of the gate/barrier openings.
- Type of gate or barrier operation: slide, swing, etc.
- Distance from the public road to the gates/barriers; minimum 30 feet. Applies to multi-family only.
- Distance from the gate to the reader.
- Location of the reader.
- Location of the "9-1-1" Box.
- Location and type of any hold open device.
- Location and type of any automatic opening device.
- Any vertical clearance obstruction.
- Confirmation that gates are to automatically open and remain open until closed manually.
- Gates/barriers must remain open at all times until a fire prevention inspector has made a final "on-site" inspection and approval.

##### **4.3.7.3 Additional Information (As May Be Required).**

Where specifically required by the fire code official the following shall be provided:

1. The Fire Marshal recommends that the "9-1-1" Box be equipped with access capability (such as a reset button or similar device) on the project side of the property so that the property management can close the gate after emergency responders leave the property.

2. Gate width openings during NORMAL or FAIL-SAFE operations shall be the same as required for the width of the private street, private drive, or access road. The full required width of the private street, private drive, or access road shall be available for use.
3. Gates/barriers shall open towards the project property, opening away from the emergency responders that may be entering the property.
4. A pin used in a “Fail-Safe” assembly shall be installed such that when the lock is removed, the pin will readily fall toward the ground (automatic swing arm gates).
5. The holes , such as the lock hole in the “9-1-1” Box or the pinhole in some “Fail-Safe” systems that use a lock, pin, or similar device shall be large enough that the lock, pin, or similar device can be easily removed.
6. Readers, telephone entry devices, or other entry devices installed within the width of a private street, private drive, or access road shall be made readily visible by means of reflective material. At least fifty percent (50%) of the height of the mounting device, pole, column, etc., shall have the reflective material provided.

#### **4.3.8 Permits Required.**

A permit is required to install and maintain a fire apparatus access-control gate or barrier on a fire apparatus access road, or a private drive or private street utilized for fire apparatus access. A permit is also required to install and maintain a “9-1-1” key box; this permit shall be renewed annually.

#### **Permit Office contact information is as follows:**

The Houston Permitting Center

1002 Washington Avenue

Houston, Texas 77002

Hours of operation: 8:00am to 3:30pm (CST)

Monday through Friday

Office phone: (832) 394-8811

To E-mail Customer Service Questions: [hfd.permitoffice@houstontx.gov](mailto:hfd.permitoffice@houstontx.gov)

Link to City Wide Fee Schedule: [www.houstoncityfees.org](http://www.houstoncityfees.org)

## **Appendix A – Automatic and Manual Swing Combination Gate**

The figure in Enclosure No. 1 illustrates an example of automatic entry with one automatic gate and one manually operated gate. Both gates will be 14 feet in width. A “9-1-1” Box and a “Fail-Safe” Box will be installed on the gate post at a height not to exceed 5 feet. For details and specifications of a “9-1-1” Box, see Appendix F, ““9-1-1” BOX AND RE-SET BOX.” The “9-1-1” Box is provided with an electrical switch (toggle or micro-switch with button). Moving the toggle switch to the “Up” position will cause the gate to swing open toward the project. The micro-switch will automatically activate once the hinged lid on the “9-1-1” Box is opened (see included drawings). The gate shall remain open until the toggle switch or hinged opening is returned to its original position.

**Note:** When approved, the “9-1-1” Box and the “Fail-Safe” Box may be combined.

### **Fail-Safe.**

If the power is off, a key provided from the “9-1-1” Box will unlock the lock attached to a pin in the arm of the operator causing the pin to fall out, thereby making the gate manually operable. In the manually operated mode, the gate shall open to the full width of the street, drive, or access road. “Duckbill” catches behind the gate will hold the gate open until manually closed or repairs are made to return the gate to normal operation, as approved. See Enclosure No. 2 and 3. When the gates are open, the full required width of the street, drive, or access road will be available for emergency use.

### **Fold-Down Hinge, Duckbill, and Similar Approved Devices.**

The other gate is a manual 14-foot “9-1-1” Access Gate. The key located in the “9-1-1” Box is the same key used to unlock the lock on the automatic gate. The key opens the lock located on a fold-down hinge (see Appendix K). When the lock is removed, the hinge falls down flat towards the project property on the street, drive, or access road, and the gate opens automatically by springs or a counterweight. “Duckbill” catches behind the gate will hold the gate open until manually closed.

**Note:** Hydraulic swing operated gates are not allowed at this time. (Hydraulic operated swing gate operations are under review for consideration at this time.)

## Enclosure No. 1 – Automatic and Manual Swing Gate Combination

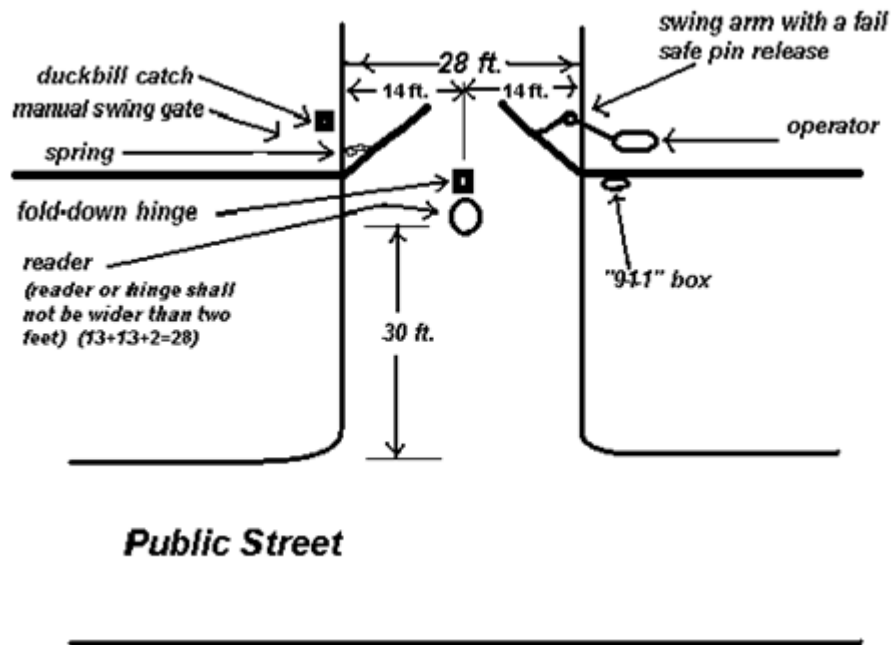

**Note:** The gate width opening is at least the same as required for the width of the private street, private drive, or access road.

## Enclosure No. 2 – “Fail-Safe” On A Swing Gate Arm

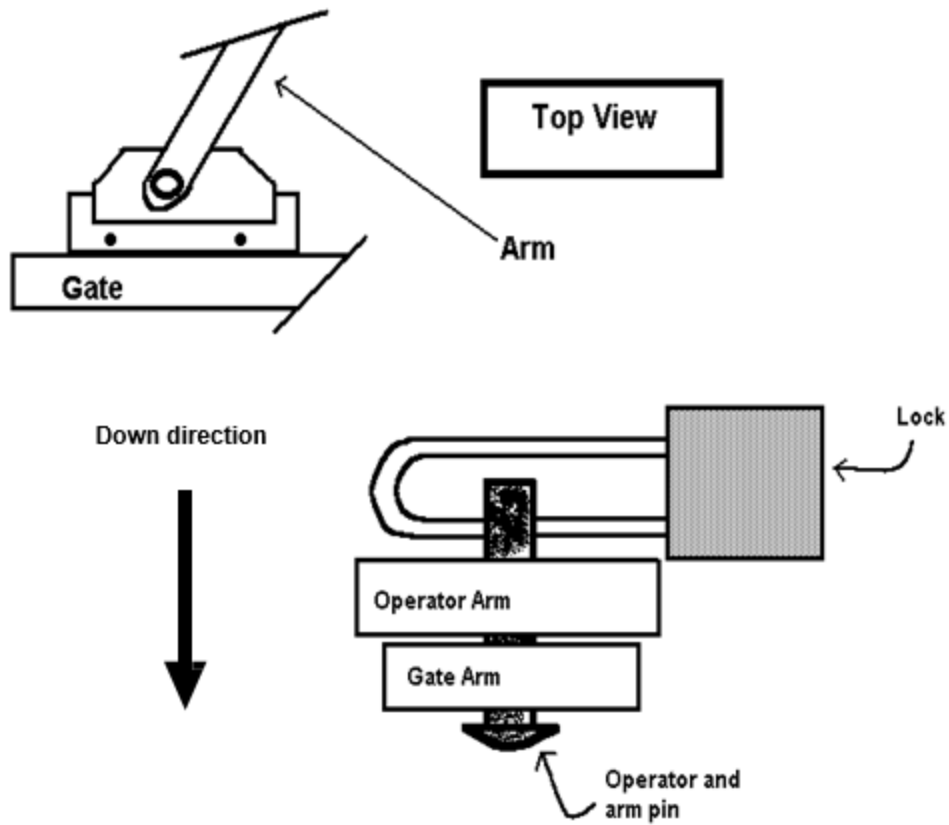

**Note:** A pin used in a “Fail-Safe” assembly shall be installed such that when the lock is removed, the pin shall readily fall toward the ground.

### Enclosure No. 3 – “Fail-Safe” On Swing Gate

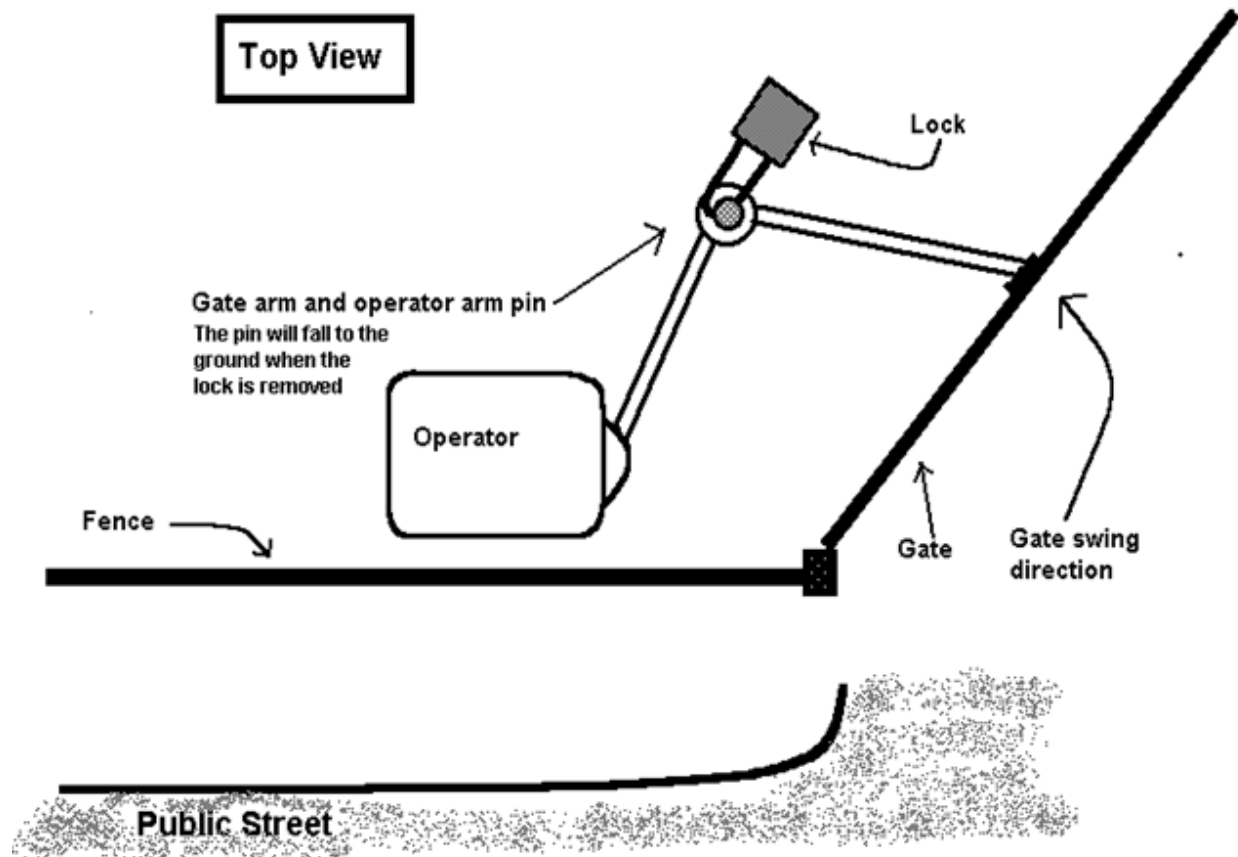

**Note:** When the operator and the gate arms are activated in the normal mode or in the “Fail-Safe” mode, the gate shall open such that the full required width of the street, drive, or access road will be available for emergency use.

## **Appendix B – Manual Swing and Automatic Slide Gate**

The figure in Enclosure No. 1 below illustrates an automatic entry with one automatic slide gate and one manual gate. Both gates will be 14 feet in width. A “9-1-1” Box and a “Fail-Safe” Box will be installed on the gate post at a height not to exceed 5 feet. For details and specifications of a “9-1-1” Box, see Appendix F, ““9-1-1” BOX AND RE-SET BOX.” The “9-1-1” Box is provided with an electrical switch (toggle or micro-switch with button). Moving the toggle switch to the “Up” position will cause the gate to swing open toward the project. The micro-switch will automatically activate once the hinged lid on the “9-1-1” Box is opened (see included drawings). The gate shall remain open until the toggle switch or hinged opening is returned to its original position.

**Note:** When approved, the “9-1-1” Box and the “Fail-Safe” Box may be combined.

### **Fail-Safe:**

The manual disconnect on the automatic slide gate will be comprised of a pull cable connected from a lock box (“Fail-Safe” Box) located on the outside edge of the gate near the “9-1-1” Box.

The adjustment bolt and a “pull pin” will pull apart at the chain so that when the cable is pulled the chain will drop at the rear of the gate. The padlock key for the gate “Fail-Safe” Box will be located in the “9-1-1” Box. The key shall be labeled for use with the “Fail-Safe” Box (drawing included).

The other gate is a manual 14-foot gate. The key located in the “9-1-1” Box is the same key used on the automatic gate “Fail-Safe.” The key opens a lock on the fold-down hinge. When the lock is removed, the hinge will fall down flat on the street, drive, or access road and the gate opens automatically by springs or a counterweight. “Duckbill” catches behind the gate will hold it open until manually closed. When the gates are open, the full required width of the street, drive, or access road will be available for emergency use.



## Enclosure No. 1 – Manual Swing and Automatic Slide Gate

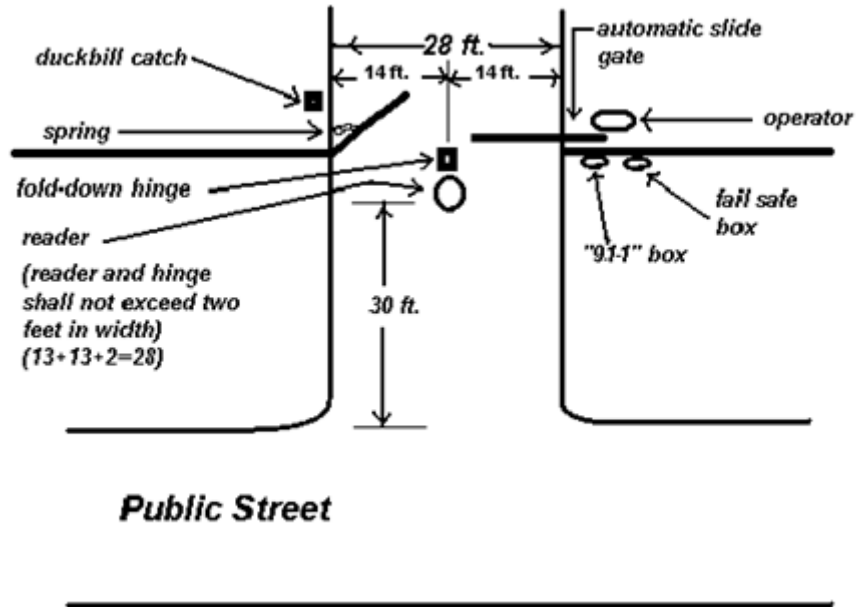

**Note:** The gate width opening is at least the same as required for the width of the private street, private drive, or access road.

## Appendix C – 13-Foot Automatic Slide Gates

### Two 13-Foot Automatic Slide Gates on a 28-Foot Access with a 2-Foot Appliance Allowance

(Appliances such as: card reader, keypad, telephone, etc.)

Gate drawing shows an automated entry with two 13-foot automatic slide gates on a 28-foot access road. The “9-1-1” Box will be mounted on the public street side of the gate as would be viewed by an emergency vehicle.

#### Fail-Safe.

Describe the “9-1-1” Box and the “Fail-Safe” feature in detail (as described in Appendix A).

The “9-1-1” Box (or an extra box if desired) will provide a manual “Fail-Safe” release (pull cable) that allows the gate to be rolled out into a full open position by manually pushing the gate. This release is functional with or without power. The gate will remain open until closed manually.

Two gates at 13 feet each are allowed if a reader is installed in the center of the access road. The reader assembly shall not exceed 2 feet in width on a 28-foot access, and 13 feet of access shall be maintained free and clear on each side of the reader.

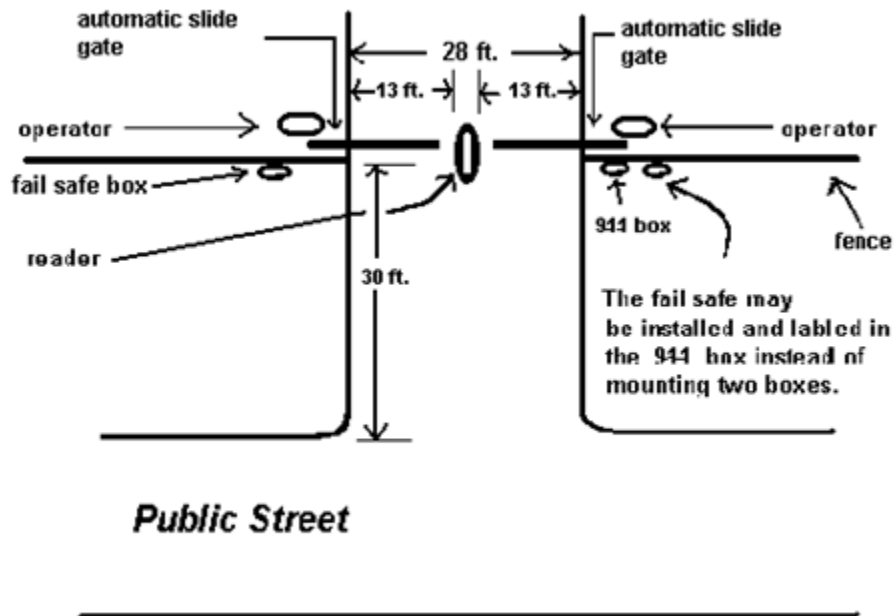

## Appendix D – 14-Foot Automatic Slide Gates

### Two 14-Foot Automatic Slide Gates with No Appliances Within The 28-Foot Access

The drawing below shows an automated entry with two 14-foot automatic slide gates on a 28-foot access road. The “9-1-1” Box will be mounted on the public street side of the gate as would be viewed by an emergency vehicle. This design is referred to as a “European Entry” which allows a free and clear 28-foot width. This is the preferred and recommended method for private streets because appliances such as readers are to the side of the access and there are no obstructions within the 28-foot street width.

#### Fail-Safe.

Describe the “9-1-1” Box and the “Fail-Safe” feature in detail (as described in Appendix A).

The “9-1-1” Box (or an extra box if desired) will provide a manual “Fail-Safe” release (pull cable) that allows the gate to be rolled out into a full open position by manually pushing the gate. This release is functional with or without power. The gate will remain open until closed manually.

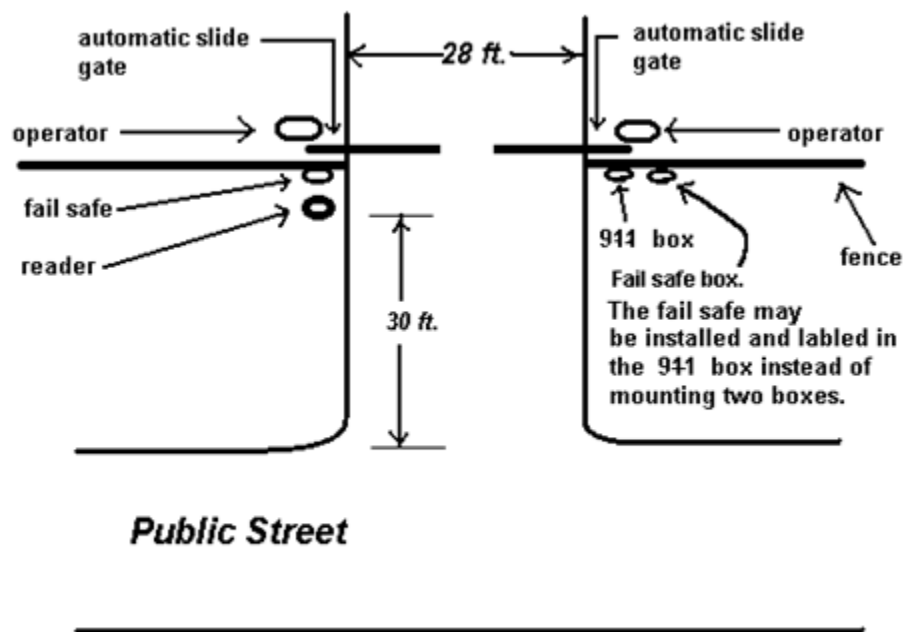

## **Appendix E – Falcon Mortise Cylinder “9-1-1” System**

### Optional – Approved Falcon Mortise Cylinder “9-1-1” System

1. “9-1-1” Mortise Box shall be totally enclosed with a mortise cylinder facing the drive (as an emergency vehicle would view on approach).
2. System shall be incorporated with the entry system and mounted not less than 5 feet in height from the road surface. The road surface is the private street, private drive, or access road.
3. Operators with no entry systems shall be placed on the gatepost or the column and mounted 42 inches in height.

For examples of “9-1-1” Mortise Boxes see Enclosure No. 1 below:

**Enclosure No. 1 – “9-1-1” Mortise Cylinder Boxes**

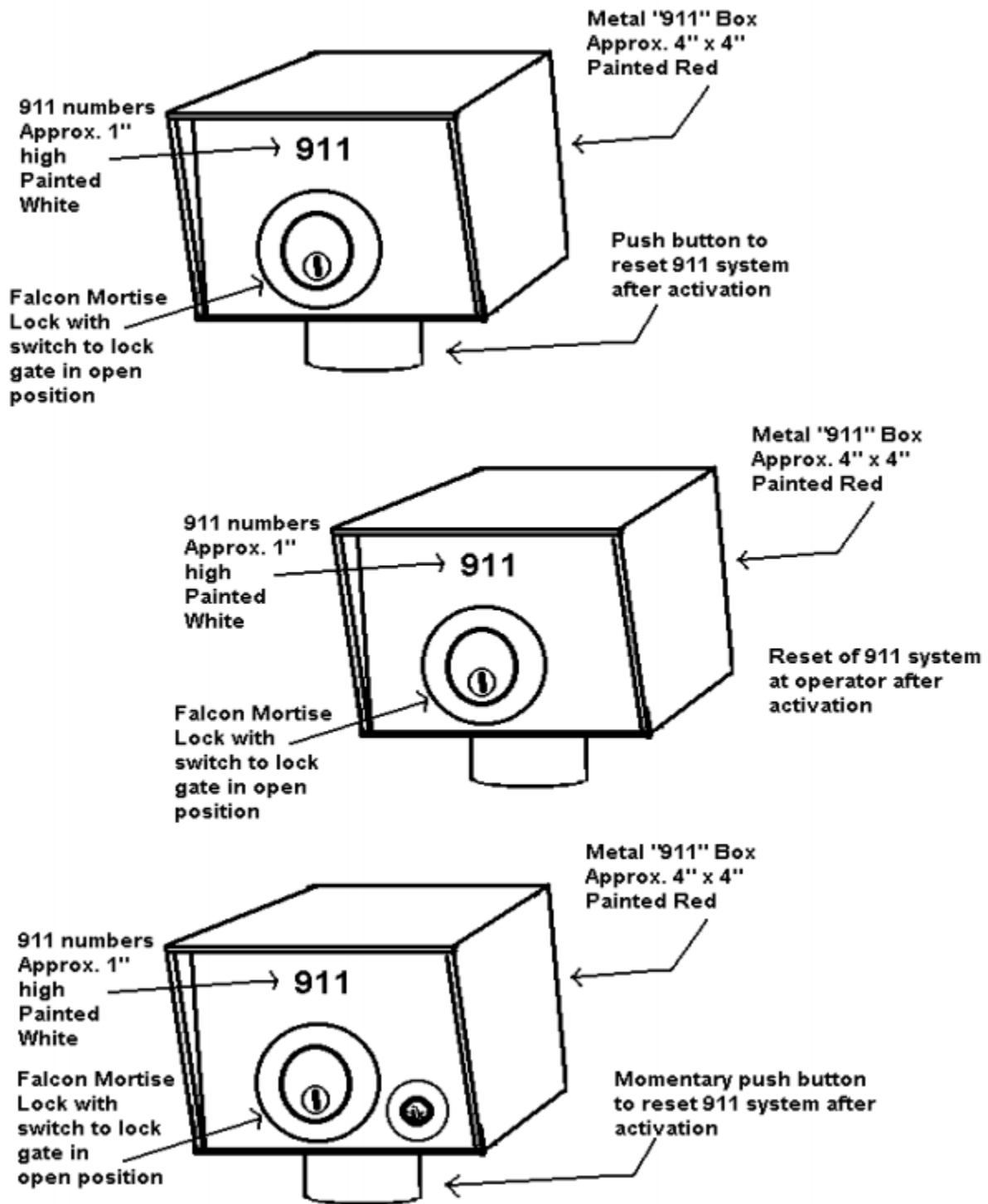

**Enclosure No. 1 – “9-1-1” Mortise Cylinder Boxes (Cont.)**

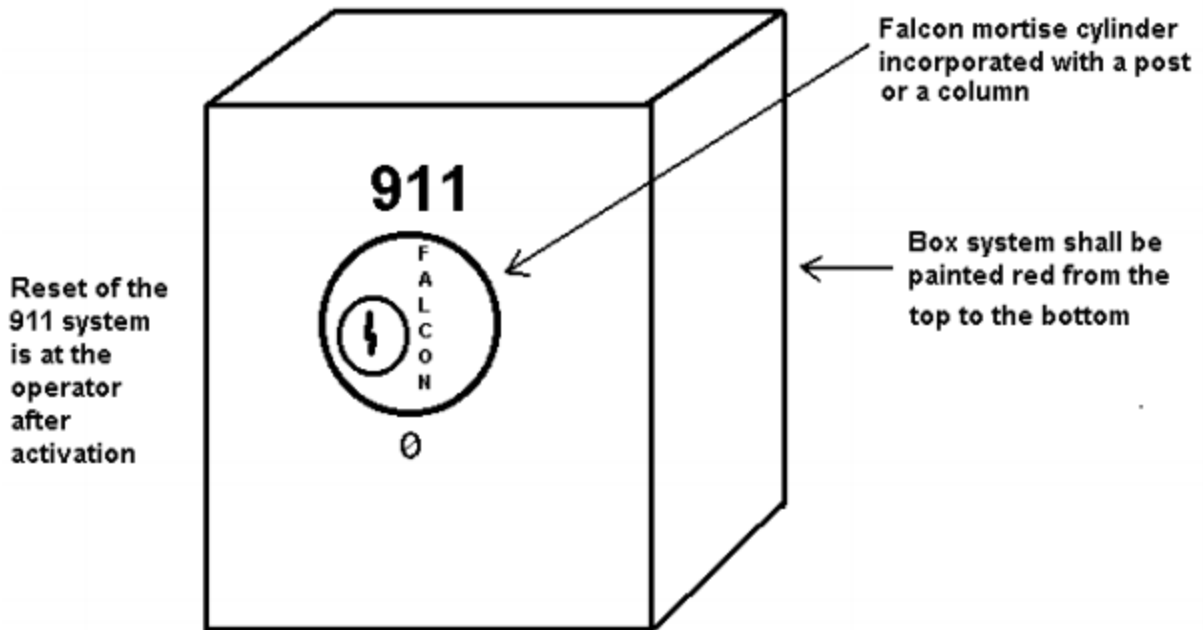
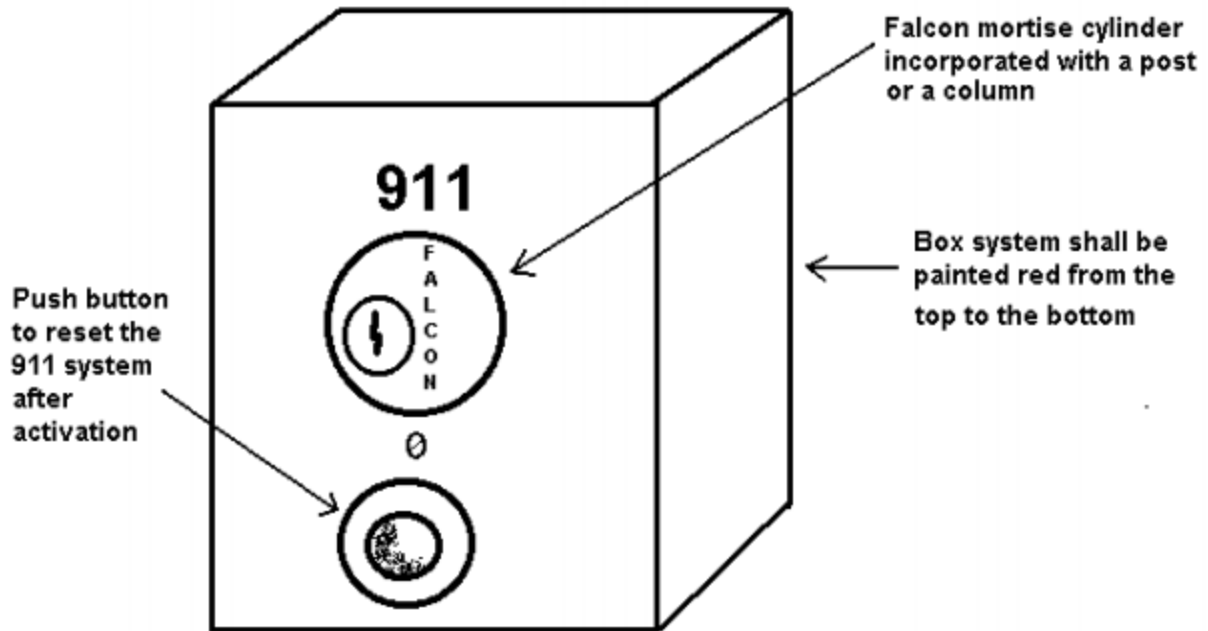

**Appendix F – “9-1-1” Box and “Re-Set” Box**

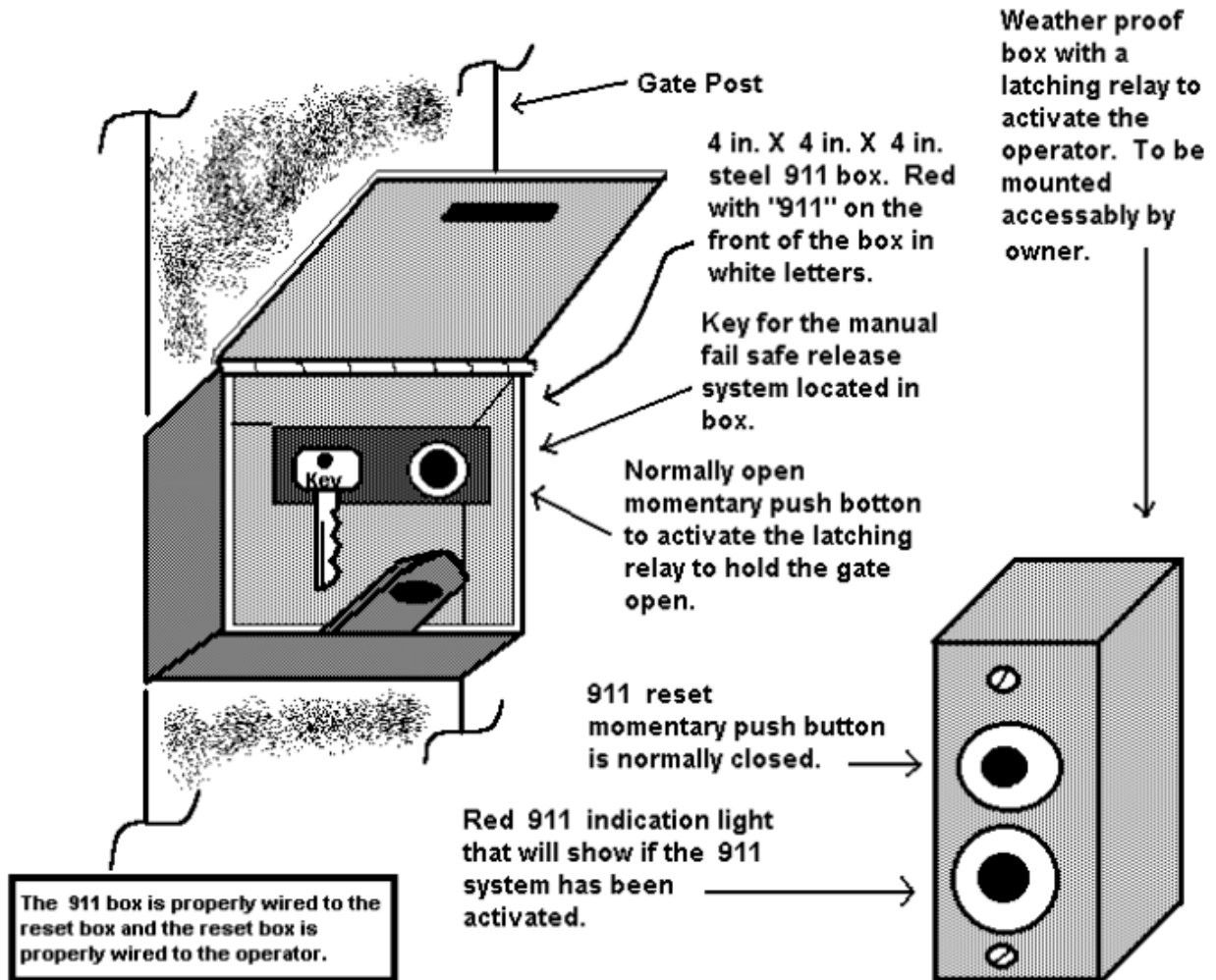





## Appendix H – “9-1-1” and “Fail-Safe” Systems on Electric Gates

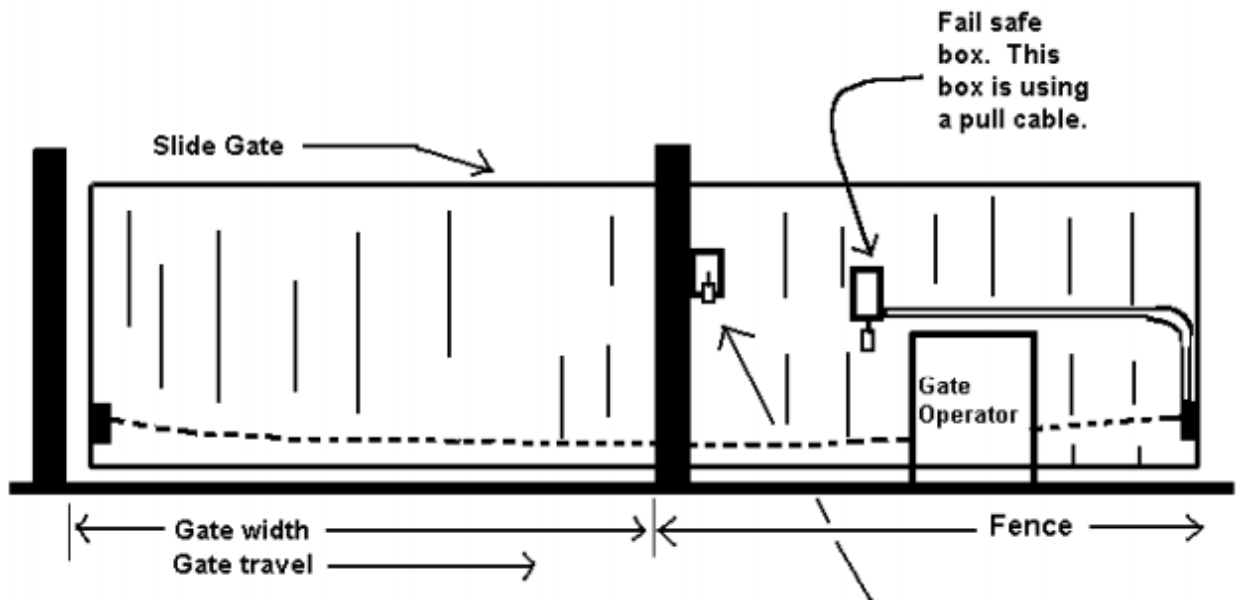

'911' box has the switch inside that will open the gate electrically. The box will also contain the key that will release the lock on the fail safe box.

The '911' box is equipped with a FALCON lock.

**Note: The gate width opening is at least the same as required for the width of the street, drive or access way.**

## Appendix I – “Fail-Safe” Cable Assembly on Electrically Operated Swing Gates

The fail safe box is mounted on the entrance side of the fence as would be viewed by emergency responders.

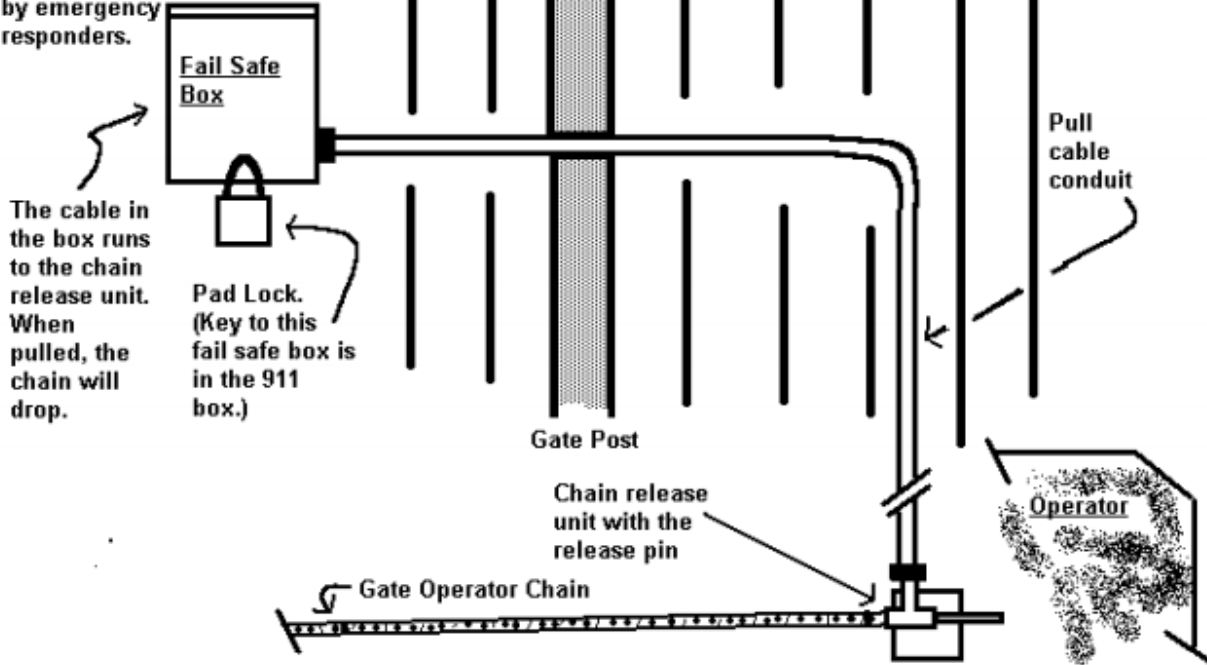

## Appendix J – “Fail-Safe” Emergency Illustration

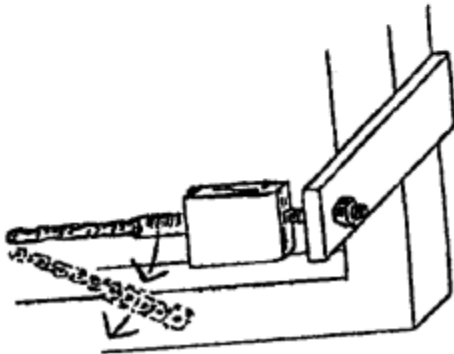
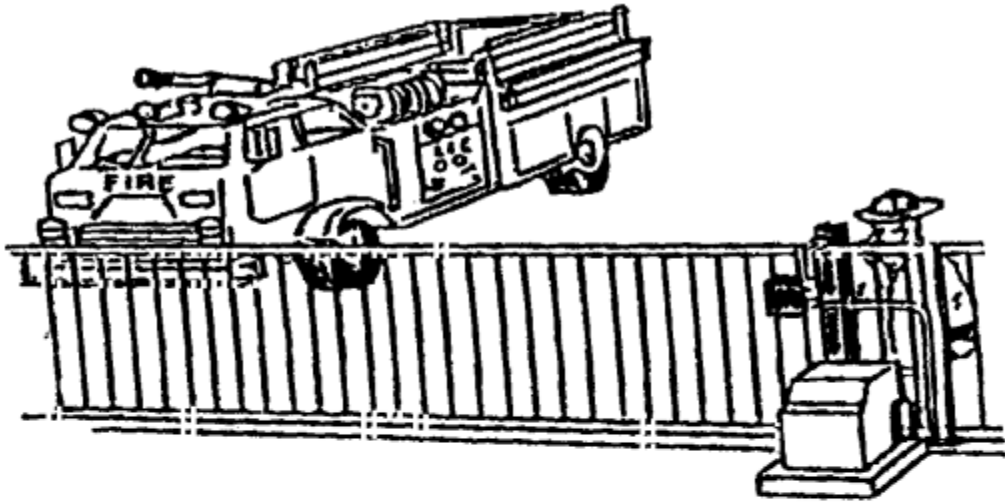

In this illustration, the firefighter or other emergency responder unlocks the Falcon Lock located on the “9-1-1” Box. He will pull the handle on the cable that causes the gate operator chain to be released as shown in the lower drawing.

At this point, the emergency responder will manually open the gate for emergency access. The gate is required to open allowing the full required width of the street, drive, or access road to be available to use.

## Appendix K – Fold Down Hinge System

To operate the gate, remove the lock by using a key located in the “9-1-1” Box. The hinge will fall forward (towards the property) and will lie flat on the street, drive, or access road. The gate will open automatically by a spring or counterweight and then will catch on the “Duckbill” catch.

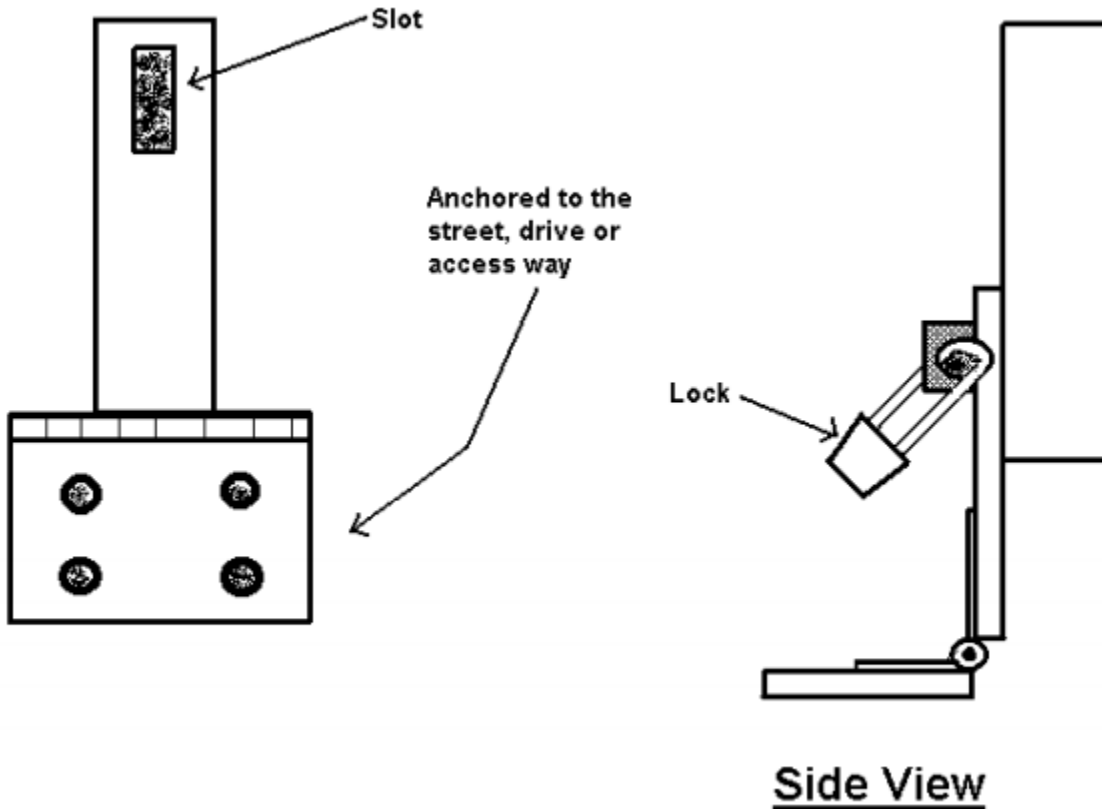

## Appendix L – Spring-Loaded “Drop Rod” Assembly

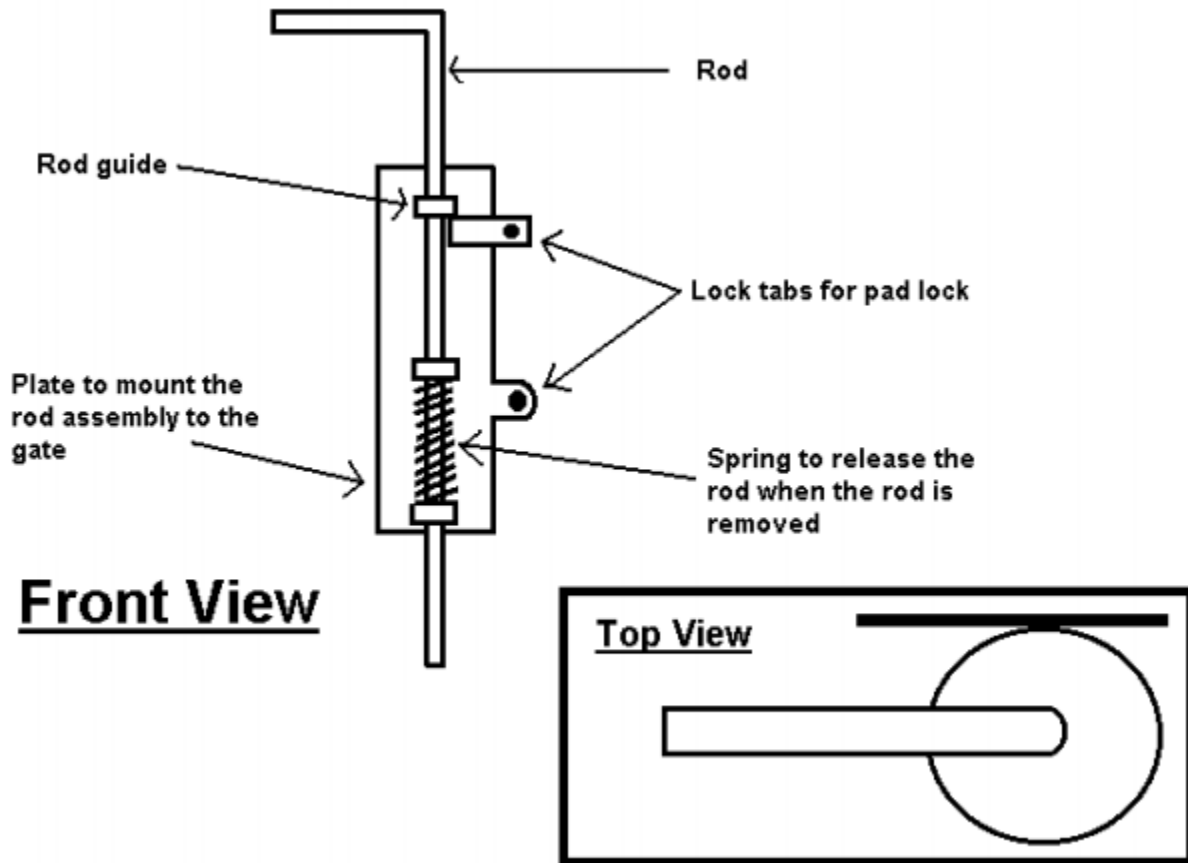

## Appendix M – Access Control Barriers

Any device or construction that restricts a fire department access road. Examples of devices or construction below:

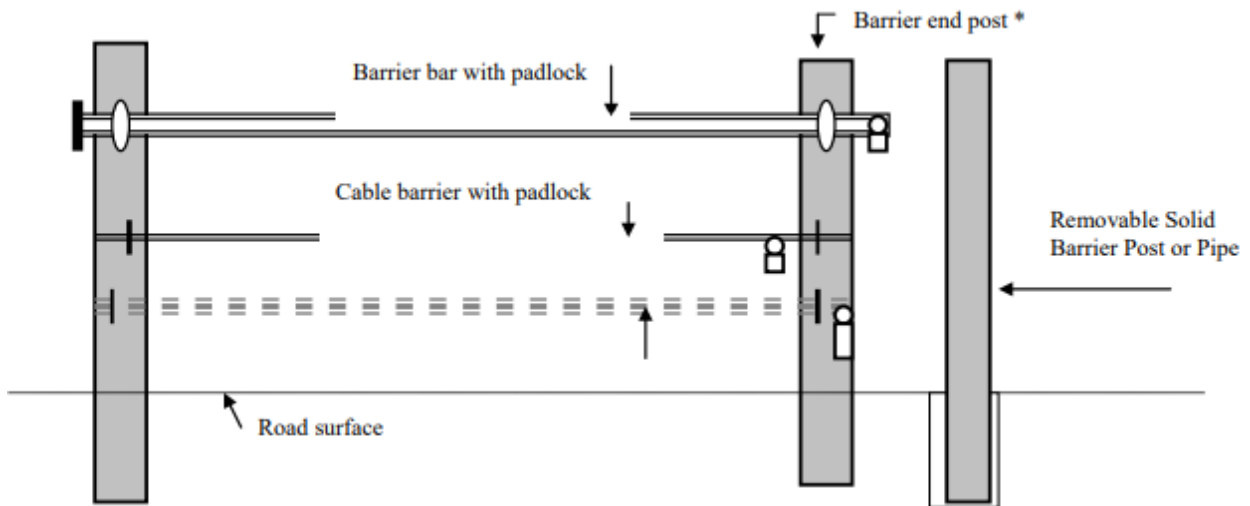

\*An approved “9-1-1” Box shall be provided, on the non-movable barrier post at the lock end of the barrier, containing the key for the lock or a release mechanism to open the barrier. (See Appendix F for description of “9-1-1” Box.)

**Note:** The barrier system is required to open allowing the full required width of the street, drive, or access road to be available for use. All swinging barriers shall be provided with a “Duckbill” catch or similar hold-open device that must be manually released.

## Appendix N – Performance Standards

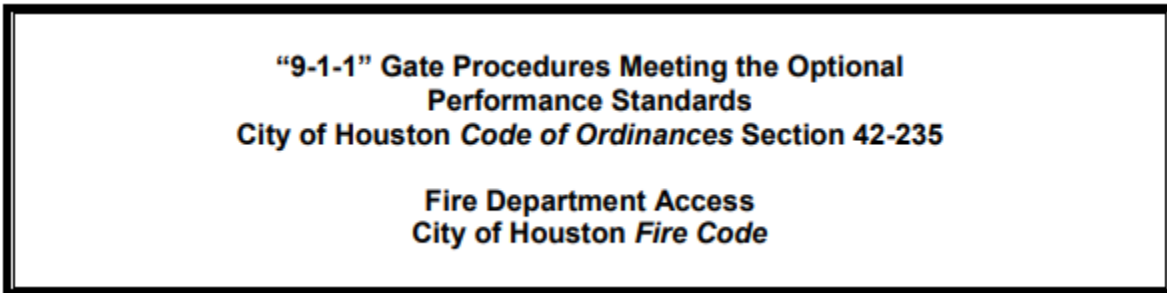

Private streets are 28 feet wide. Access roads less than 28 feet but not less than 20 feet in width may be considered, provided that compliance with the *Performance Standards* have been met and approved by the City of Houston *Planning and Development Department*.

### ***Where can I find the Performance Standards?***

The Performance Standards come from the City of Houston *Code of Ordinances*, Section 42-235.

To use this option, you must also be familiar with the requirements of Division 6, Multi-Family Residential Developments regarding *private streets*.

### ***Can I install equipment inside the width of my access road under the Performance Standards?***

Access roads of 26 feet or less shall not have obstructions within the width of the access road under the requirements of the Performance Standards.

This means that card readers, telephone entry devices, remote control devices, and other equipment shall be installed in a manner referred to as a “European Entry.” This means that the street is free and clear of obstructions. Equipment may be installed within the curbside area.

## Appendix O – Procedure for Submittal for Gate (Barrier) Approvals

### Step 1:

1. Applications – Make application at the City of Houston Permit Office, 1002 Washington Ave; telephone: (832) 394-8811, for the following approvals:
  - a) Installation of “9-1-1” Access Control Gate/Barrier  
(Application made by the installer of the gate or barrier)Or,
  - b) Access Control Gate/Barrier, to maintain (operate) “9-1-1” Gate/Barrier  
(Application made by property management or owners)

**Note:** This is an annual permit (must be renewed every year).
2. At the Permit Office, furnish a *Deed Restriction* and *Law Compliance Affidavit* and the information for the permit application.

**Note:** The signature on the affidavit and on the permit must be the same individual.

### Step 2:

Obtain the *Plot Plans* of the property or a letter from the City of Houston Planning Department. City Planning is located downtown at 611 Walker Street.

### Step 3:

Provide 3 sets of *plans* that show all entrances and access points to the property from the public street(s).

Plans must show dimensions and information, such as:

- Width of the gate/barrier openings.
- Type of gate or barrier operation: slide, swing, etc.
- Distance from the access roads to the gates/barriers.
- Distance from the gate to the reader.
- Location of the reader (card reader, key pad, telephone entry, etc.).
- Location of the “9-1-1” Box, with WHITE numbers (9)(1)(1) on the box contrasting to the RED “9-1-1” Box.
- Location and type of the hold open devices.
- Location and type of the automatic opening device(s).
- Any vertical clearance obstructions.
- Names of the public streets in the immediate area.
- Or any other necessary information.

### Step 4:

Provide a “Letter of Explanation” that fully explains the type of operation and “Fail-Safe” system.



**Note:** No electronic or battery backup “Fail-Safe” operation shall be used. All “Fail-Safe” operations shall be MANUAL.

**Step 5:**

Take the paid copy or receipt that you should have received at the Permit Office and the letter or plat drawing obtained from the City Planning Department (611 Walker Street), along with 3 drawings (referred to as plans above), and your “Letter of Explanation”, to the Senior Fire Inspector, at the Fire Marshal’s Office, located at Fire State #70, 11410 Beamer Road.

See a clerk to have your paperwork placed in the inter-office mail for the Senior Inspector over “9-1-1” Gate/Barrier plans review.

After being delivered to the Fire Marshal’s Office, the paperwork will be forwarded to the Senior Inspector. Plans are reviewed according to the order that they are received.

Plans will be approved or they will be disapproved. You should be notified within one to two weeks after the date that the plans are received. If you have any questions or require further information or assistance you may contact the Fire Marshal’s Office to obtain the phone number for the fire prevention inspector reviewing the “9-1-1” Access Gate/Barrier plans for approval.

## Appendix P – Key Boxes

Figure No. 1 – Typical Key Box/"9-1-1" Box (Open with Padlock Removed)

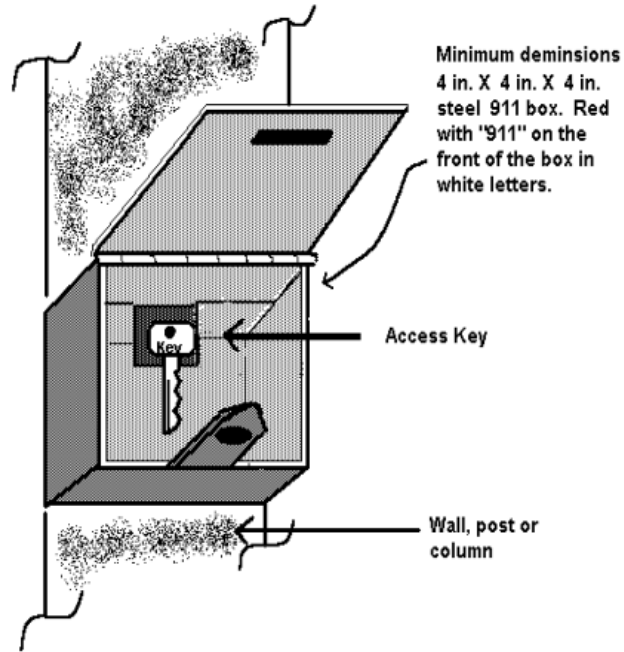
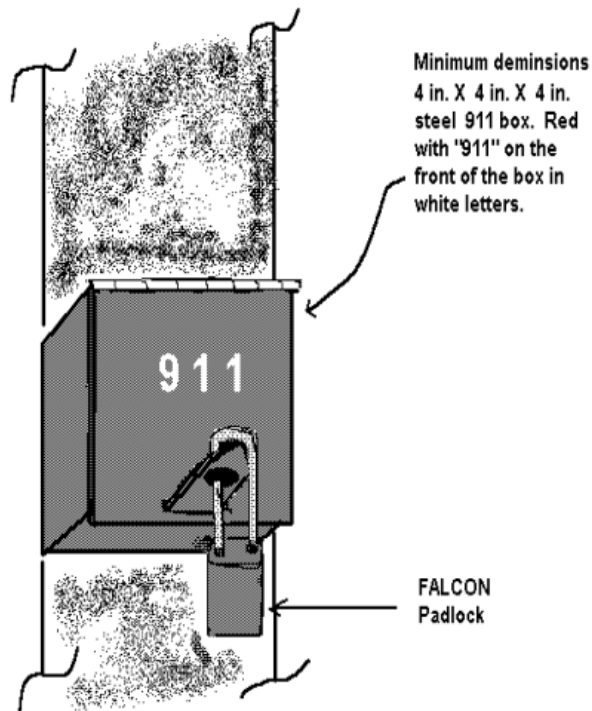
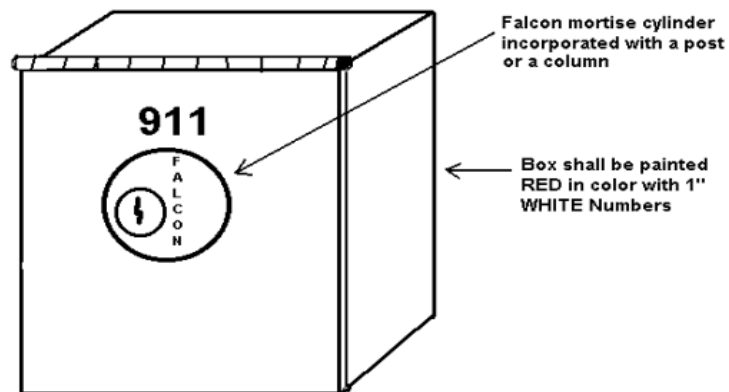

Figure No. 2 – Typical Key Box/"9-1-1" Box (Closed with Padlock)



**Figure No. 3 – Key Box/”9-1-1” Box with Falcon Mortise Cylinder**



**References**

1. City of Houston *Fire Code*.
2. City of Houston *Code of Ordinances*, Section 42-235.

All reference materials used under this Life Safety Bureau standard shall be in accordance with the most current adopted City of Houston *Construction Code*.