

Notes:

1. Provide hurricane strapping as per Appendix L of the City of Houston Residential Code.
2. The under-floor grade shall be cleaned of all vegetation and organic material (section R408.5).
3. All exterior footings shall be placed at least 12 inches below the undisturbed ground surface (section R 403.1.4).

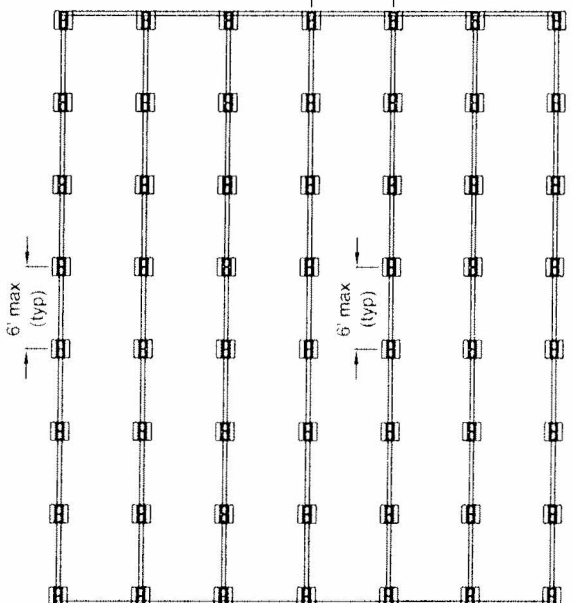
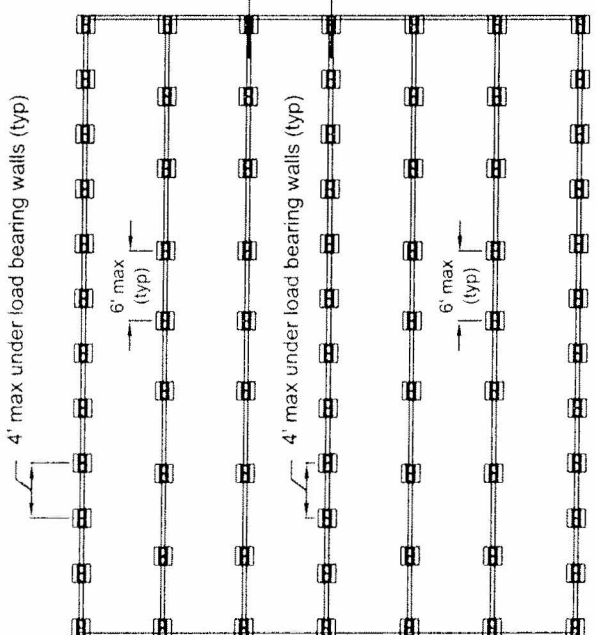
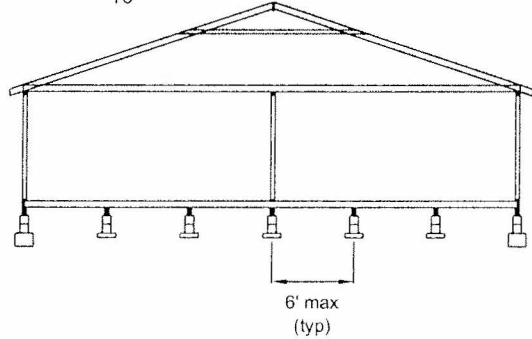
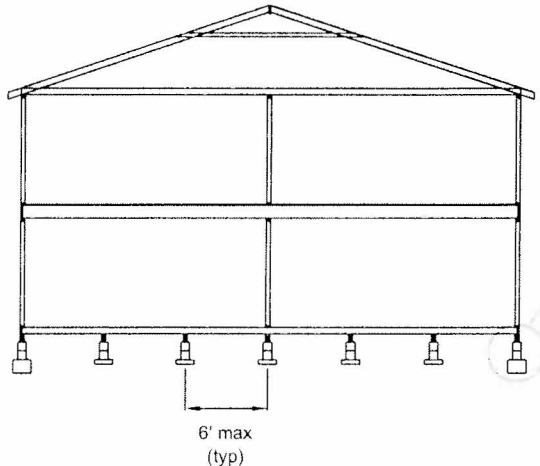
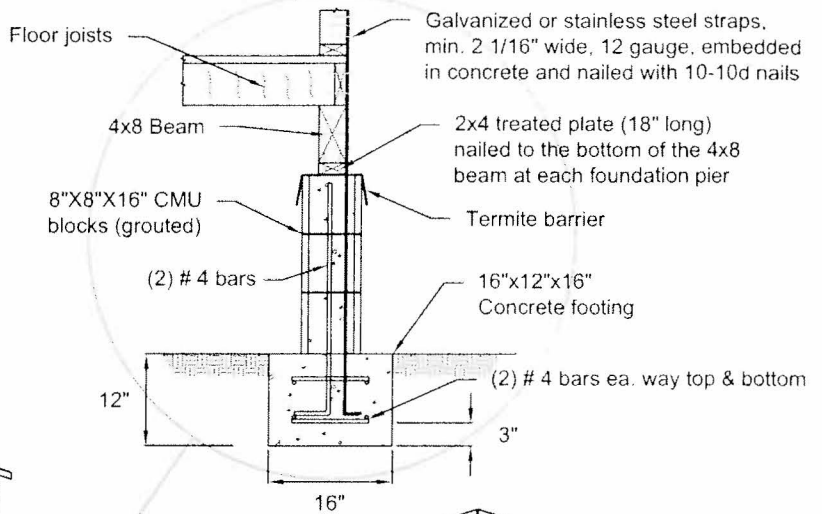

TWO-STORY RESIDENCE

ONE STORY RESIDENCE



STANDARD DRAWING
CITY OF HOUSTON
 DEPARTMENT OF PUBLIC
 WORKS & ENGINEERING

**BLOCK & BASE FOUNDATIONS
 DETAILS**
 1002 WASHINGTON AVE., HOUSTON, TEXAS 77002

APPROVED BY: *[Signature]*
 BUILDING OFFICIAL
 APPROVED BY: *[Signature]*
 CITY ENGINEER
 DATE: 10-02-2013 DWG NO: 13-05-R 1 OF 1