



TRANSIENT METER APPLICATION PROCEDURES

Transient Meter applications can be submitted Monday through Friday, from 8:00AM until 3:30PM at the Houston Permitting Center located at 1002 Washington Ave., Houston, TX 77002 – 3rd Floor with the Taps and Meters Section. For any inquiries regarding application status or deposits, please call Taps & Meters at (832) 394-8888 or email to tapechs@houston.tx.gov. You may call to schedule the appointment **AFTER** the application is approved, the required deposit is paid, and you have received a WNS #. To schedule an appointment, please call the **Transient Water Meter Section at (832) 395-6285** between 8:00 am and 3:30 pm, Monday through Friday. Transient Meters can be delivered to a specific job site within 48 to 72 hours after the appointment is scheduled. For any appointment or billing inquiries, please email Transient.meters@houston.tx.gov.

****PLEASE PROVIDE THE FOLLOWING REQUIREMENTS****

1. An original letter on the company's letter head requesting a transient meter. The letter should state the purpose of the meter, size requested, service address, billing address, valid company tax ID number, the representative's name, phone number, e-mail and driver's license of the company's representative to be present must match the information in the letter. *(Please be advised that the Representative is accepting responsibility for the terms of the Rental Agreement and any unauthorized use of the transient meter.)*
2. The following deposits are based on the size of the meter being requested and is required, please call for availability: 1 INCH - \$500.00, 2 INCHES - \$1,000.00, 3 INCHES - \$1,500.00. (ONLY CASH, CASHIER'S CHECK OR MONEY ORDER IS ACCEPTED). A \$29.72 Administration Fee will be applied for cancellation requests for transient meters.
3. The company representative applying will be required to have an approved Backflow Prevention Device for each transient meter and shall provide the following information:

Backflow Prevention Type: <input type="checkbox"/> RPZ <input type="checkbox"/> Air Gap		Mount Method: <input type="checkbox"/> Stationary <input type="checkbox"/> Truck	
RPZ Make/Model:	Serial#	Size:	Cert. Test Date:
Key Map:	Service Address:		

4. Upon installation of the Backflow Prevention device, please provide the following:
 - a. The City of Houston registered tester must enter the Backflow Prevention Assembly Certified Test Report into XC2 Live and pay a fee. Please email a copy of the test report to HPWCrosscon@houston.tx.gov. You may contact Emily Chacon at 832 395-3865 for any questions.
 - b. Mail or fax a copy of this report to the City of Houston Transient Water Meter Section, 4200 Leeland, Houston, TX 77023. Fax number (713) 371-1294.
 - c. Tester List https://www.publicworks.houston.tx.gov/cross_connection_control

Monthly reading forms will be mailed to your company each month. A company representative must read the meter on the 11th of the month and record the reading on this form. Meter readings must be received in our office by the 16th of each month. Readings may be called in to our office at (832) 395-6285, faxed to (713) 371-1294, E-mailed to: transient.meters@houston.tx.gov or mailed to: City of Houston Transient Meter Section, 4200 Leeland, Houston, TX 77023.

**CITY OF HOUSTON
TRANSIENT METER RENTAL AGREEMENT**

Customers who require the use of a transient meter must complete an application and rental agreement at 1002 Washington Ave., Houston, TX 77002 – 3rd Floor with the Taps and Meters Section.

Rental agreement will be for a form of twelve (12) months from the date of application shown below. Customers who want to continue use of the transient meter after the expiration date must reapply on or before the expiration date of the rental agreement. If the customer fails to return the transient water meter(s) or renews the rental agreement on or before the expiration date, the entire amount of the customer's deposit will be forfeited.

Customers must pay a deposit to secure the City of Houston against any loss, theft, damage, or unpaid water charges. Deposits charges are based on transient meter size as follows:

- 1" - \$500.00
- 2" - \$1,000.00
- 3" - \$1,500.00

The deposit, less any outstanding charges, will be refunded to the customer upon the expiration or cancellation of this agreement.

Rates for water usage through a transient water meter shall be as specified in Section 47-61. In addition to water usage, a rental fee will be charged for each month or portion of a month the meter is held by the transient meter customer. Rates will be based on meter size as follows:

- 1"- \$95.00
- 2" - \$185.00
- 3" - \$460.00

All transient meter and appurtenances will be installed by an authorized City of Houston personnel and shall be made available for reading and inspection during normal business hours of the City of Houston.

Customer must provide a Back-flow Preventer or an Airgap to a tank storage facility. A certificate of calibration must be provided before City of Houston personnel can install the transient meter.

Customers must contact the City of Houston Transient Meter Department at (832) 395-6285 to schedule an appointment for installation of the transient meter. Appointments may be scheduled between the hours of 8:00 am – 3:30 pm, Monday through Friday, except holidays.

Truck mounted transient meters will be installed at the City of Houston Meter Shop located at 2700 Dalton St, Houston, Texas 77017. Customers must schedule an appointment and bring the vehicle to the City of Houston Meter Shop for installation.

City of Houston personnel will install stationary transient meters at the project site provided. Customers must schedule an appointment to have meters installed. Your company representative must be present during the installation of the meter.

The entire amount of the customer's deposit will be forfeited if any transient meter is moved from its original location or tampered with. The deposit is also forfeited in the event of theft and a police report will be required to be submitted. Customers will be required to make another deposit if they wish to continue using the transient meter or the rental agreement will be canceled, and the customer will be required to return the transient meter to the City of Houston Meter Shop.

In the event the applicant requires to have the transient meter relocated after installation, it shall be the duty of the applicant to request the authorized City of Houston personnel to relocate the meter. A charge of \$29.64 shall be assessed for the relocation of a transient meter. The only exception to this is if the transient meter is classified as truck mounted during initial application.

Name of Company:	Phone:
Billing Address:	Fax:
*Name of Responsible Party:	
*E-mail of Responsible Party:	
Signature of Co. Representative:	Date:

OFFICE USE ONLY

APPLICATION DATE: _____

EXPIRATION DATE: _____



The City of Houston Ordinance and Plumbing Code Requirements For Water Usage from The Fire Hydrant

As per City of Houston Water and Sewer Ordinance No. 47-23 & 47-30 and City of Houston Plumbing Code, no person shall make or allow a connection to exist with the fire hydrants within the corporate limits of City of Houston or area served by the city of Houston unless authorized by the department, on a temporary service for construction purposes and there is a City of Houston issued Transient Meter provided at the hookup.

A transient meter application can be made to the Utility Analysis Section/Taps & Meters located at 1002 Washington Ave, 3rd Fl. Houston, TX 77002.

Furthermore, you must use an "Air Gap" to the portable water tank or an approved Reduces Pressure Zone Backflow Prevention Assembly at each Transient Meter hookup. An approved "Air Gap" shall be at least two times the diameter of the supply pipe measure vertically above the top of the overflow rim of the vessel & in no case less than one (1) inch.

The Backflow Prevention Assembly shall be tested upon the installation & annually thereafter. No factory testing is accepted. The original copy of the test report completed by a City of Houston Registered Backflow Tester must be submitted to: Meter Shop, 2700 Dalton St, Houston, TX 77017 upon picking up the Transient Meter.

Any questions regarding the Backflow Prevention Assembly, City Customer Tester List & Cross Connection Control Program shall be addressed to the Water Quality & Cross Connection Control Group at 7000 Ardmore, Houston, TX 77054, Phone (832) 395-3800.

The latest copy of the City Customer Tester List can be downloaded from the City of Houston's Website:

<https://edocs.publicworks.houstontx.gov/division-files/public-utilities-division/cross-connection-control/1393-tester-list.html>

Pursuant to the City of Houston Plumbing Code, Section 102, violation of the above or any provision of this code shall continue a misdemeanor punishable upon conviction by a fine not less than \$250.00 and not more than \$2,000.00.

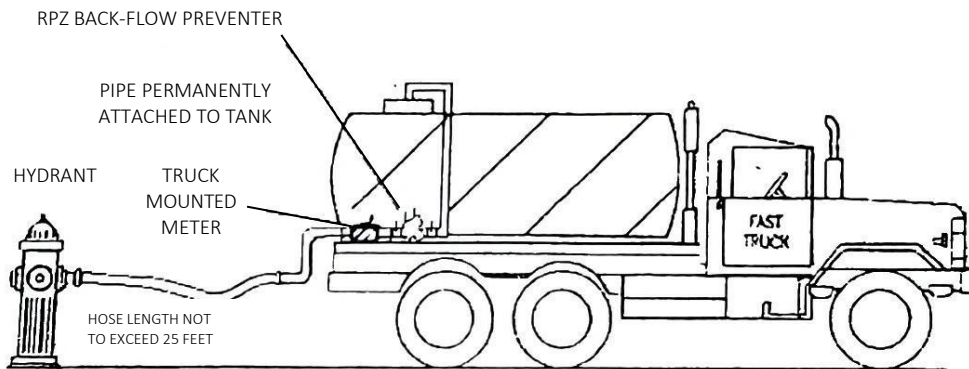
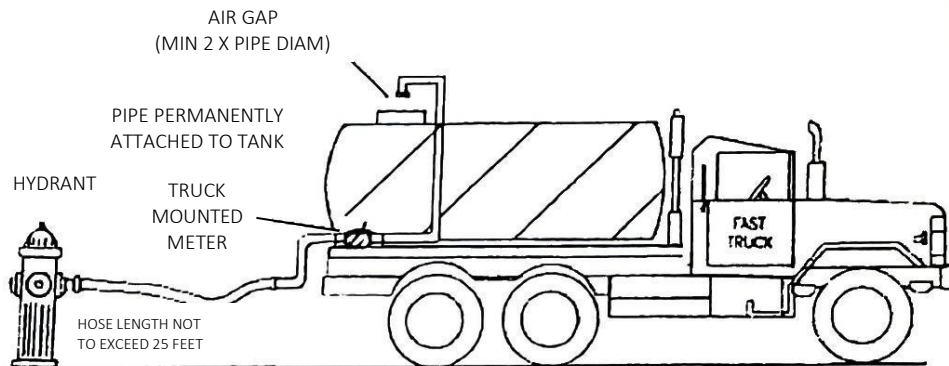

CITY OF HOUSTON

DEPARTMENT OF PUBLIC WORKS AND
ENGINEERING, CONSTRUCTION AND REAL ESTATE
GROUP

PROPER METHODS
OF FILLING PORTABLE
WATER TANK SYSTEMS

APPROVED BY:

CITY ENGINEER

APPROVED BY:

DIRECTOR OF PUBLIC WORKS

SCALE: NONE

DATE: 1/1/2017

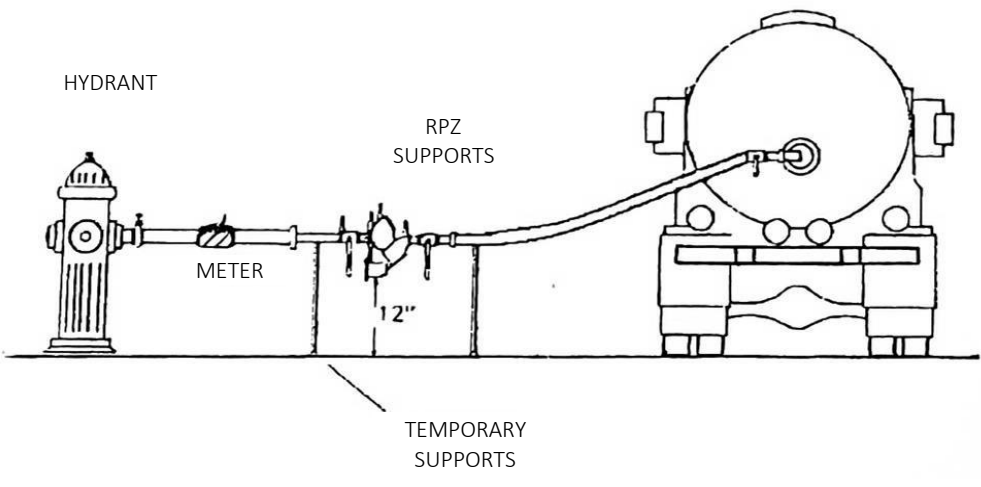
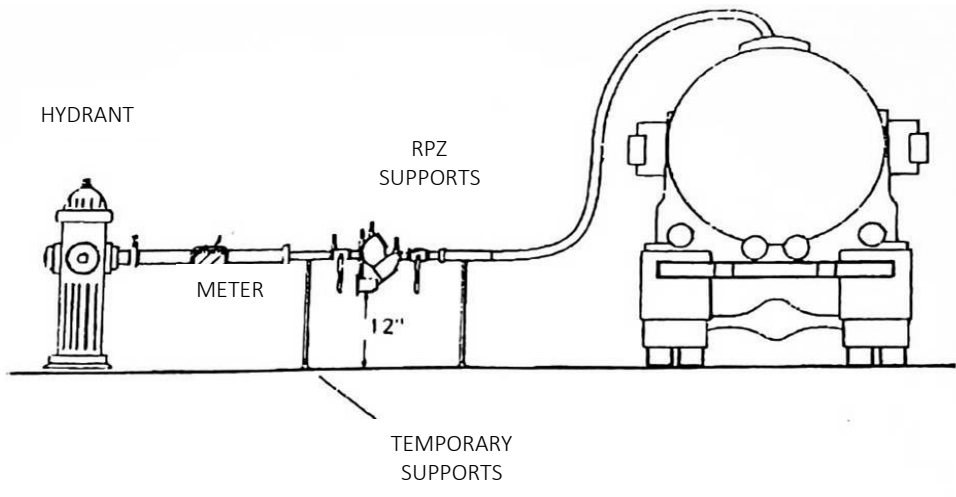

<p>CITY OF HOUSTON</p> <p>DEPARTMENT OF PUBLIC WORKS AND ENGINEERING, CONSTRUCTION AND REAL ESTATE GROUP</p>	
<p>PROPER METHODS OF FILLING PORTABLE WATER TANK SYSTEMS</p>	
<p>APPROVED BY:</p> <p>_____</p> <p>CITY ENGINEER</p>	<p>APPROVED BY:</p> <p>_____</p> <p>DIRECTOR OF PUBLIC WORKS</p>
<p>SCALE:</p> <p>NONE</p>	
<p>DATE: 1/1/2017</p>	